

Carrier Trailer Refrigeration

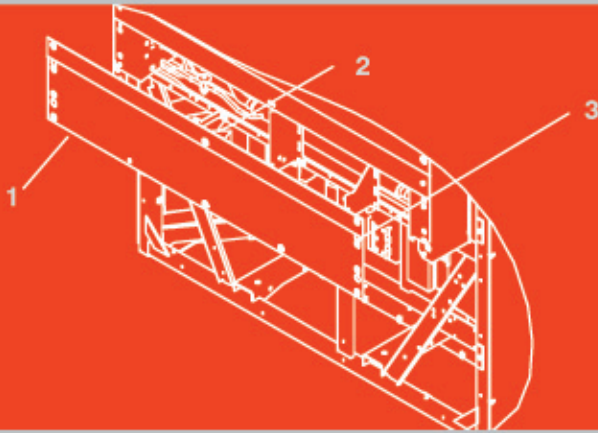

SERVICE PARTS LIST
for
X2 2100 A/R AND
X2 2500 A/R
Trailer and Rail Refrigeration Units



TRANSICOLD

SERVICE PARTS LIST
for
X2 2100 A/R AND
X2 2500 A/R
Trailer and Rail Refrigeration Units

TABLE OF CONTENTS

PARAGRAPH NUMBER	Page
INTRODUCTION	i
MODEL CHART	i
ORDERING INSTRUCTIONS	i
GENERAL NOTES	i
1 QUICK LIST	1
1.1 COMPRESSOR	1
1.2 QUICK LIST - BELTS	1
1.3 QUICK LIST - ENGINE	1
1.4 QUICK LIST - CLAMPS	1
1.5 QUICK LIST - FILTERS	2
1.6 QUICK LIST - FUSES	2
1.7 QUICK LIST - HARNESSSES	2
1.8 QUICK LIST - SWITCHES, TRANSDUCERS AND THERMISTORS	3
1.9 QUICK LIST - REFRIGERATION: COILS, VALVES, VIBRASORBERS, HEAT EXCH	3
1.10 QUICK LIST - INSTALLED OPTIONS	4
1.11 O-RING FACE SEAL FITTINGS AND O-RINGS	5
2 FRAME ASSEMBLY	6
3 SKINS	8
3.1 SKINS - HINGES	8
3.2 SKINS - ROADSIDE AND CURBSIDE OUTER DOORS	10
3.3 SKINS - ROADSIDE AND CURBSIDE FRONT DOORS	12
3.4 SKINS - CONDENSER GRILL	14
3.5 SKINS - UPPER AND LOWER BACK PANELS	16
4 REFRIGERATION	18
4.1 REFRIGERATION - AIR SWITCH AND HARDWARE	18
4.2 REFRIGERATION - TUBING	20
4.2.1 REFRIGERATION - DISCHARGE LINE	22
4.2.2 REFRIGERATION - HOT GAS LINE	23
4.2.3 REFRIGERATION - KING VALVE AND SV2 VALVE	24
4.2.4 REFRIGERATION - SUCTION LINE	25
5 EVAPORATOR ASSEMBLY	26
5.1 FRAME AND POD	26
5.2 EVAPORATOR - POD HARDWARE	27
5.3 EVAPORATOR - BLOWER ASSEMBLY AND EVAPORATOR COIL	28
5.4 EVAPORATOR - HARDWARE	30
5.5 EVAPORATOR - TUBING AND WIRING	32
6 FRESH AIR EXCHANGE - AFAX	34
7 POWER TRAIN	35
7.1 UPPER POWER TRAIN - FRONT VIEW	35
7.1.1 UPPER POWER TRAIN - IDLER ASSEMBLY	36
7.2 POWER TRAIN - FAN SHAFT AND CLUTCH	38
7.3 POWER TRAIN - DRIVE	40

TABLE OF CONTENTS

PARAGRAPH NUMBER	Page
8 UNIDRIVE ASSEMBLY	41
8.1 UNIDRIVE - MOUNTING AND ENGINE	41
8.2 UNIDRIVE - COMPRESSOR ASSEMBLY	42
8.3 UNIDRIVE - HIGH PRESSURE SWITCH, IDLER AND V-BELT MOUNTING	43
8.3.1 UNIDRIVE - IDLER ASSEMBLY	44
8.4 ALTERNATOR ASSEMBLY	46
8.4.1 ALTERNATOR	48
9 FUEL FILTER	50
9.1 STANDARD FUEL FILTER	50
9.2 FUEL KIT - DAVCO & DAVCO WITH HEATER	52
9.2.1 DAVCO FUEL FILTER	54
9.3 FUEL HOSE & FITTING - RAIL ONLY	55
10 COOLANT KIT - RUBBER / SILICONE & ECR RUBBER - WITH & WITHOUT SENSOR	56
11 AIR CLEANER ASSEMBLY	58
12 EXHAUST SYSTEM	59
13 ELECTRICAL	60
13.1 HARDWARE AND HARNESSSES	60
13.2 CONTROL BOX	62
13.3 ENGINE HARNESS	66
13.4 CONTROL BOX HARNESS	68
13.5 ADVANCE MICROPROCESSOR ASSEMBLY - DISPLAY MODULE	70
14 BATTERY AND ANTI-THEFT OPTION	72
15 DECALS	74
16 PACKAGING	76
17 LOW-NOISE	78
18 FIELD INSTALLED KITS	80
18.1 BUMPERS	80
18.1.1 MICRO BUMPER AND BOTTOM PANEL KITS	80
18.1.2 BOTTOM BUMPER KIT	82
18.1.3 CONDENSER BUMPER KIT	84
18.2 EVAPORATOR DRAINLINE EXTENSION KIT	86
18.3 TOP GRILL KIT	86
18.4 FUEL PUMP KIT	88
18.5 LIGHTBAR KIT - STANDARD AND LED	90
18.6 REMOTE TEMPERATURE PROBE KIT - 75 & 100 FT	92
18.7 REMOTE PANEL KIT - FLUSH MOUNT	94
18.8 LOW-FUEL SHUTDOWN KIT	96
18.9 DOOR SWITCH SHUTDOWN & REMOTE SWITCH KITS	98
PART NUMBER INDEX	Index-1

INTRODUCTION

This parts list identifies service replacement parts for the Carrier Transicold Models listed in Model Chart below. This parts list does not include detailed replacement parts for the engine or compressor listed in the first chart below. Detailed parts identification for these items may be found in the applicable parts list manuals referred to in the second chart.

MODEL CHART

Unit		Engine	Compressor
Model No.	Name	Refrigerant	Engine Type
NDL93SN	X2 2100A	R-404A	V2203-DI ESC
NDL93SR	X2 2100R		
NDL93UN	X2 2500A		
NDL93UR	X2 2500R		
			41CFM 05G

MANUAL/ FORM NO.	PART NUMBER COVERED	EQUIPMENT COVERED	TYPE OF MANUAL/FORM
62-11168	26-00120-00/-01	V2203-DI ESC	Engine Parts List
62-11053	18-00091-105	05G Twinport Compressor	Compressor Parts List

ORDERING INSTRUCTIONS

All orders and inquiries for parts must include:

- Unit Serial Number
- Part Number
- Description of Part
- Quantity Required

Address all correspondence for parts to the following address:

CARRIER TRANSICOLD DIVISION
 Replacement Components Group
 TR-20, P.O. Box 4805
 Syracuse, New York 13221
 or
 Fax to: (315) 432-3778

GENERAL NOTES

To find replacement parts, consult table of contents, and turn to the appropriate page for the illustrated breakdown of replacement parts. The following letter designations are used to classify parts throughout this list:

The following letter designations are used to classify parts throughout this list:

A/R *As Required.*

P-- *Suffix P--* added to the part number means the part is available in a packaged quantity only.
 Example: P/N34-00373-01P10 is a package of 10 P/N34-00373-01. Use the part number and the P-- suffix when ordering.

PL *Purchase locally.*

SST *Stainless Steel* - 300 Series unless otherwise specified.

SV *Suffix SV* - added to the part number designates service part replacement part.

1 QUICK LIST	
1.1 COMPRESSOR	
Part Number	Description
18-00091-105	COMPRESSOR, 41 CFM, 05G TWINPORT
1.2 QUICK LIST - BELTS	
50-00178-26	V-BELT, COND FAN, BX SECTION, X2 2500A/R
50-00178-24	V-BELT, COND FAN, BX SECTION, X2 2100A/R
50-00178-19	V-BELT, B SECTION, LOWER DRIVE
50-00162-25	V-BELT, NOTCHED, WATERPUMP / ALTERNATOR
1.3 QUICK LIST - ENGINE	
26-00120-00	ENGINE, KUBOTA, X2 2500A/R - INCLUDES:
26-00120-01	ENGINE, KUBOTA, X2 2100A/R - INCLUDES:
30-00463-00P12	OIL FILTER, ESI (SOLD IN CASE OF 12 ONLY)
25-39316-00	STARTER
1.4 QUICK LIST - CLAMPS	
30-00175-01	CLAMP, U-BOLT, 5/16-18 X 2.00 DIAMETER
34-00172-05	CLAMP, HALF, 3/4"
34-00373-01	CLAMP, TUBE, .25 DIA CUSHION
34-00373-03	CLAMP, TUBE, .38 DIA CUSHION
34-00373-05	CLAMP, TUBE, .50 DIA CUSHION
34-00373-06	CLAMP, TUBE, .56 DIA CUSHION
34-00373-07	CLAMP, TUBE, .62 DIA CUSHION
34-00373-50	CLAMP, TUBE, .19 DIA CUSHION
34-00373-51	CLAMP, TUBE, .25 DIA CUSHION
34-00373-69	CLAMP, TUBE, 1.38 DIA CUSHION
44-00045-05	CLAMP, HOSE, 2.06-3.00 WORM TYPE
44-00045-20	CLAMP, HOSE, 3.06-4.00"
44-00045-26	CLAMP, HOSE, .31-.88 WORM TYPE
44-00102-01	CLAMP, CUSHIONED, .50" DIAMETER
44-00102-02	CLAMP, CUSHIONED, .56 DIAMETER
44-00102-06	CLAMP, CUSHIONED, .88 DIAMETER
44-00102-18	CLAMP, CUSHIONED, .38 DIAMETER
44-00285-20	CLAMP, TUBE, 1-3/8" OD 3 PCS
44-00285-22	CLAMP, TUBE, 1-1/2 OD 3 PCS
44-00285-60	CLAMP, TUBE, 7/8 OD 3 PCS
44-00285-72	CLAMP, TUBE, 7/8 OD 4 PCS
44-00293-06	CLAMP, STEPLESS EAR, 7/16 DIA
44-00293-07	CLAMP, STEPLESS EAR, 15/32" DIA
44-01028-13	CLAMP, CUSHIONED, 1-3/8 DIA (2 HOLE)
44-01134-04	CLAMP, CUSHIONED, .25 DIA (HIGH TEMP)
44-01134-08	CLAMP, CUSHIONED .50 DIA (HIGH TEMP)
44-01137-19	CLAMP, CONDUIT, 16MM DIA
44-01140-06	CLAMP, HOSE, 3.75-4.50 (WORM)
44-01168-00	CLAMP, HOSE, FUEL LINE
44-01170-23	CLAMP, HOSE, 23MM (0.90") DIA

1.4 QUICK LIST - CLAMPS (Continued)

44-01170-36	CLAMP, HOSE, 36MM (1.41") DIA
44-01170-41	CLAMP, HOSE, 41MM (1.61") DIA
58-00712-15	CLAMP, HOSE, SNAP, .985-1.135 O.D.
68-07729-00	CLAMP, DRAIN PAN HEATER LINE

1.5 QUICK LIST - FILTERS

14-00209-00	FILTER DRIER, 1/2 SAE FLARE - INCLUDES:
14-00209-20	O-RING, DRIER
30-00463-00P12	FILTER, OIL, ESI, (CASE OF 12)
30-01090-04	FILTER, FUEL, W/ WATER SEP. AND DRAIN - INCLUDES:
30-01090-11	DRAIN, FUEL FILTER (W/ O-RING)
30-01079-01	FILTER ELEMENT, FUEL, BOWL TYPE
30-01106-25	FILTER ELEMENT, FUEL, DAVCO, W/ O-RINGS
30-00471-20	FILTER ELEMENT, AIR FILTER
30-01108-20	FILTER, FUEL PUMP (80 MICRON)

1.6 QUICK LIST - FUSES

22-00060-03	FUSE, 15 AMP
22-00060-35	FUSE, 10 AMP, F10
22-01661-00	FUSEHOLDER, IN-LINE, F10, FOR ABOVE 10 AMP FUSE
22-02336-01	FUSE, 20A, FUEL HEATER ONLY
22-02336-04	FUSE, 10A
22-02336-09	FUSE, 80 AMP, MAXIFUSE, F5
22-50078-61SV	FUSE HOLDER AND COVER ASSY, MAXIFUSE, F5
22-02336-10	FUSE, 1 AMP
22-02336-19	FUSE, MINI, 3A
22-02338-03	FUSE HOLDER, FOR ABOVE 3A MINI FUSE
22-02336-21	FUSE, 5 AMP, F7
22-02338-05	FUSEHOLDER, IN-LINE, F7, FOR ABOVE 5 AMP FUSE
22-50078-22SV	FUSE HOLDER AND COVER ASSY, F9, AFAS - INCLUDES:
22-02336-03	FUSE, 3 AMP, F9
22-50078-22SV	FUSE HOLDER AND COVER

1.7 QUICK LIST - HARNESSSES

22-01951-00	HARNESS, DTT
22-01951-01	HARNESS, RAS
22-04048-01	HARNESS, ENGINE
22-01943-00	HARNESS, ATS
22-04025-00	HARNESS, CONTROL BOX
22-04025-01	HARNESS, CONTROL BOX, W/ AFAX
22-04042-00	HARNESS, DISPLAY
22-02824-01	HARNESS, REEFERTRAK CONTROL
22-02839-00	HARNESS, FUEL LEVEL SENSOR
22-60287-01	HARNESS, FUEL PUMP
22-01940-00	HARNESS ASSY, REMOTE SENSOR
22-02809-00	HARNESS ASSY, PULP PROBE
22-01857-00	HARNESS, REMOTE SENSOR, 75 FT
22-01857-01	HARNESS, REMOTE SENSOR, 100 FT
22-02810-00	HARNESS, REMOTE PANEL
76-60798-05	EXTENSION HARNESS, REMOTE PANEL, 5 METERS (16.4 FT)

1.7 QUICK LIST - HARNESSSES (Continued)

76-60798-10	EXTENSION HARNESS, REMOTE PANEL, 10 METERS (32.8 FT)
76-60798-15	EXTENSION HARNESS, REMOTE PANEL, 15 METERS (49.2 FT)
76-60798-20	EXTENSION HARNESS, REMOTE PANEL, 20 METERS (65.6 FT)
12-60040-00	SERIAL PORT INTERFACE / SPLITTER, RS232

1.8 QUICK LIST - SWITCHES, TRANSDUCERS AND THERMISTORS

10-00375-01SV	BUZZER, WARNING, W/ O-RING
10-01129-15SV	SWITCH, TOGGLE, ON/OFF
10-01129-16SV	SWITCH, TOGGLE, GLOW/CRANK
12-00284-00	THERMISTOR, COMPRESSOR TEMP
12-00303-00	SWITCH, AIR PRESSURE, W/ BRACKET
12-00309-04	SWITCH, PRESSURE 465/350 PSIG HP1
12-00342-03	SENSOR, THERMISTOR (PULP PROBE ONLY)
12-00352-03SV	TRANSDUCER, SUCTION PRESS
12-00352-04	TRANSDUCER, DISCHARGE PRESSURE, 0/500 PSIG HP2
12-00419-03	MAGNET, DOOR SWITCH
12-00419-04	SWITCH, MAGNETIC, DOOR
12-00495-02SV	THERMISTOR, DTT / ATS
12-00523-00	SENSOR, THERMISTOR (TEMP PROBE ONLY)
12-00523-01	THERMISTOR, RAS / SAS
12-00592-00	SWITCH, OIL PRESSURE
12-00601-00	SENSOR, COOLANT LEVEL
12-01145-03	THERMISTOR, ENGINE TEMP
12-01147-01	SENSOR, LOW FUEL (IN TANK)
22-50251-01	KILL SWITCH ASSY, REEFERTRAK
30-00328-01	INDICATOR, AIR FILTER (FILTER MINDER)

1.9 QUICK LIST - REFRIGERATION: COILS, VALVES, VIBRASORBERS, HEAT EXCHANGERS

08-00306-00	COIL, CONDENSER / RADIATOR, X2 2500 A/R ONLY
08-00305-00	COIL, CONDENSER / RADIATOR, X2 2100 A/R ONLY
08-00225-02	COIL, EVAPORATOR
14-00199-00	VALVE, CHECK, RECEIVER PRESSURIZATION
14-00263-03	VALVE, SOLENOID, SUCTION MODULATION, SMV
14-00331-00	VALVE, CHECK, DISCHARGE, 90°
14-00324-01	VALVE, SOLENOID, W/ STUB-OUTS, SV1 - INCLUDES:
14-01114-20	COIL, SOLENOID VALVE - INCLUDES
14-00308-00	VALVE, SERVICE, SUCTION W/ 1-3/8" STUB-OUTS
14-00309-03	VALVE, SERVICE, DISCHARGE, W/ 7/8" STUB-OUTS
14-00310-01	VALVE, KING, W/ 1/2" STUB-OUTS
14-00348-05	VALVE/TUBE ASSY, W/ COIL & STUB-OUTS, SV2 - INCLUDES:
14-00348-04	VALVE/TUBE ASSY, W/ COIL & STUB-OUTS, SV4 - INCLUDES:
14-00350-03	VALVE, SOLENOID, LESS COIL
22-02579-00	COIL, (SV2 / SV4) SOLENOID VALVE
14-00322-00	STRAINER ASSY, DISCHARGE
65-00182-03	RECEIVER ASSY
73-00201-00	VIBRASORBER, DISCHARGE
73-00328-10	VIBRASORBER, SUCTION, W/ COVER

1.9 QUICK LIST - REFRIGERATION: COILS, VALVES, VIBRASORBERS, HEAT EXCHANGERS (Cont)

81-01653-01	HEAT EXCHANGER ASSY, X2 2500 A/R - INCLUDES:
81-01653-02	HEAT EXCHANGER ASSY, X2 2100 A/R - INCLUDES:
08-00197-01	HEAT EXCHANGER, LSHX
14-00232-28	VALVE, EXPANSION, TXV, X2 2500 A/R ONLY
14-00232-25	VALVE, EXPANSION, TXV, X2 2100 A/R ONLY
14-00176-02	STRAINER, TXV, 100 MESH
22-02804-00	COIL, COMPRESSOR UNLOADER
10-00591-00	SOLENOID, PUSH, 12 VDC, FRESH AIR, AFAX

1.10 QUICK LIST - INSTALLED OPTIONS

76-00561-00	BATTERY ANTI-THEFT KIT
76-00559-00	BUMPER KIT, MICRO, STAND ALONE
76-00571-00	BUMPER KIT, LOWER (REQUIRES 76-00559-00 MICRO BUMPER)
76-00524-00	BUMPER KIT, UPPER (CONDENSER)
76-00554-00	INSTALL KIT, EVAP DRAIN EXTENSION
76-00566-00	FUEL HOSE AND FITTINGS KIT, RAIL ONLY
76-00578-07	SHUTDOWN KIT, LOW FUEL
76-00725-01	SHUTDOWN KIT, DOOR SWITCH
76-00295-06	FUEL PUMP KIT
76-00535-01	MICRO BOTTOM PANEL KIT
76-00542-00	LIGHTBAR KIT, STANDARD
76-02000-00	LIGHTBAR KIT, L.E.D.
76-00725-00	REMOTE TEMP PROBE KIT, 75FT
76-00725-03	REMOTE TEMP PROBE KIT, 100FT
76-00725-02	REMOTE PULP PROBE KIT, 75FT
76-60876-07	REMOTE PANEL KIT, FLUSH MOUNT
76-00556-00	TOP GRILL KIT
76-02001-00	LOWER BACK PANEL KIT

1.11 O-RING FACE SEAL FITTINGS AND O-RINGS

TUBE SIZE - OD	SLEEVE P/N	NUT P/N	O-RING P/N	MALE ORS FITTING
1/4"	40-60008-01	40-60009-01	42-00243-10	40-60007-01
3/8"	40-60008-02	40-60009-02	42-00243-09	40-60007-02
1/2"	40-60008-03	40-60009-03	42-00243-04	40-60007-03
5/8"	40-60008-04	40-60009-04	42-00243-03	40-60007-04
7/8"	40-60008-07	40-60009-06	42-00243-00	40-60007-11

2 FRAME ASSEMBLY

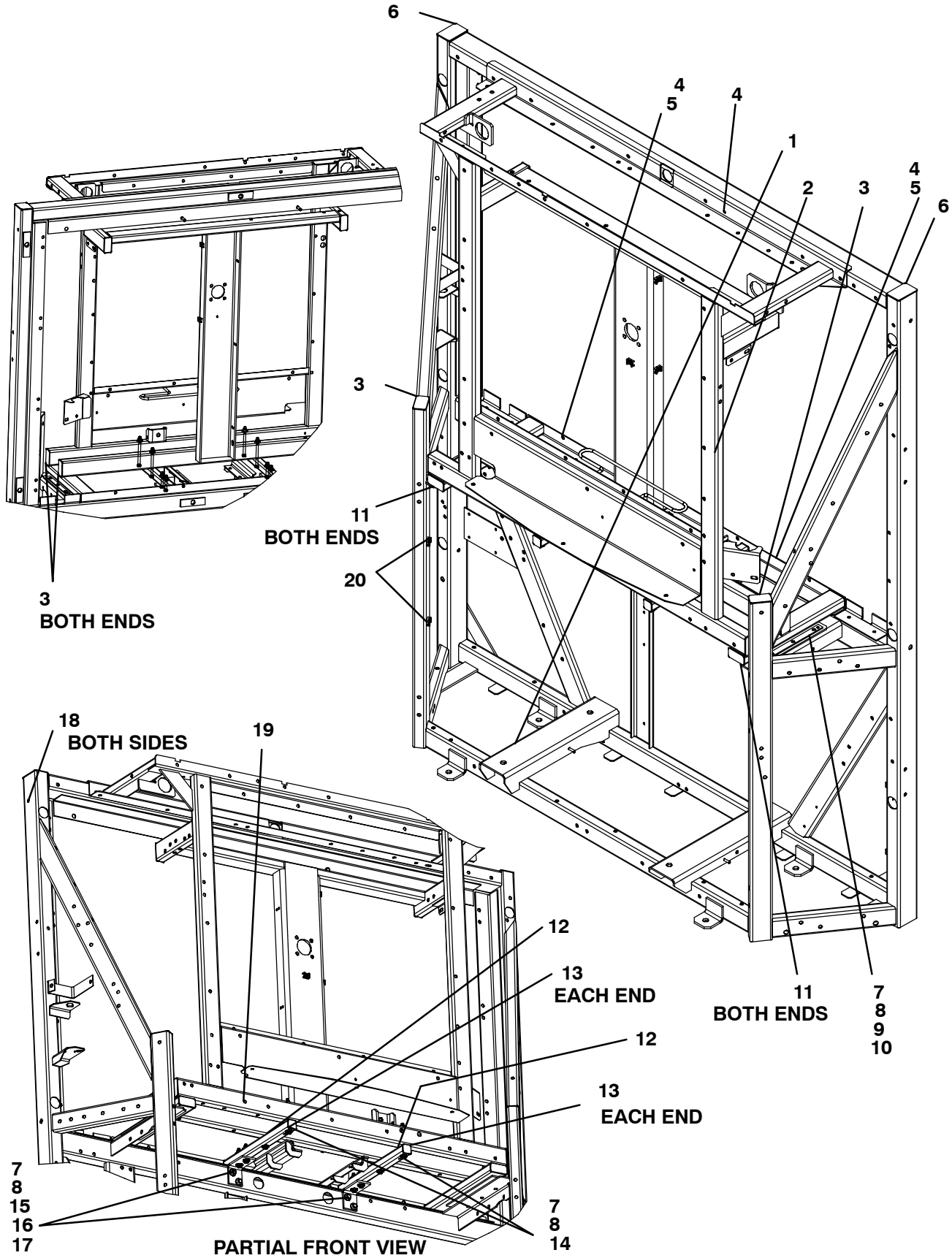

2 FRAME ASSEMBLY

Item	Part Number	Description	Qty
1	86-04621-00	FRAME ASSEMBLY MAIN	1
2	86-04620-00	FRAME ASSEMBLY CONDENSER	1
3	58-04099-02	PLUG, RUBBER, 1.280 X 2.280 RECT.	6
4	34-01294-08	SCREW, CAPT. WASH, 1/4-20 X 1.00	19
5	68-07876-00	ANGLE, EVAP MOUNTING	2
6	58-04099-04	PLUG, RUBBER, 1.737 X 2.737 RECT.	2
7	34-00361-12	NUT, SELF LOCK, 5/16-18	14
8	34-00366-12	WASHER, PLAIN, 5/16"	32
9	34-00302-10	SCREW, CAP HXHD, 5/16-18 X 1.25	6
10	68-11579-00	PLATE, WASHER	2
11	58-04099-01	PLUG, RUBBER, 1.110 X 2.360 RECT.	4
12	68-14943-00	TUBE, FRAME, FRONT TO BACK	2
13	58-04099-06	PLUG, RUBBER, 1.25 X 1.25 RECT.	4
14	34-00615-36	SCREW, CAP HXHD, 5/16-18 X 2.00	4
15	34-00615-18	SCREW, CAP HXHD, 5/16-18 X 2.25	4
16	34-00919-08	SCREW, HX WASHHD, 5/16-18 X 1.00	4
17	68-14944-01	ANGLE, FRAME TUBE	2
18	34-06051-10	RIVNUT, 5/16-18	6
19	34-06051-06	RIVNUT, 1/4-20	A/R
20	58-04507-00	HOLDER, WIRE TIE	10

3 SKINS

3.1 SKINS - HINGES

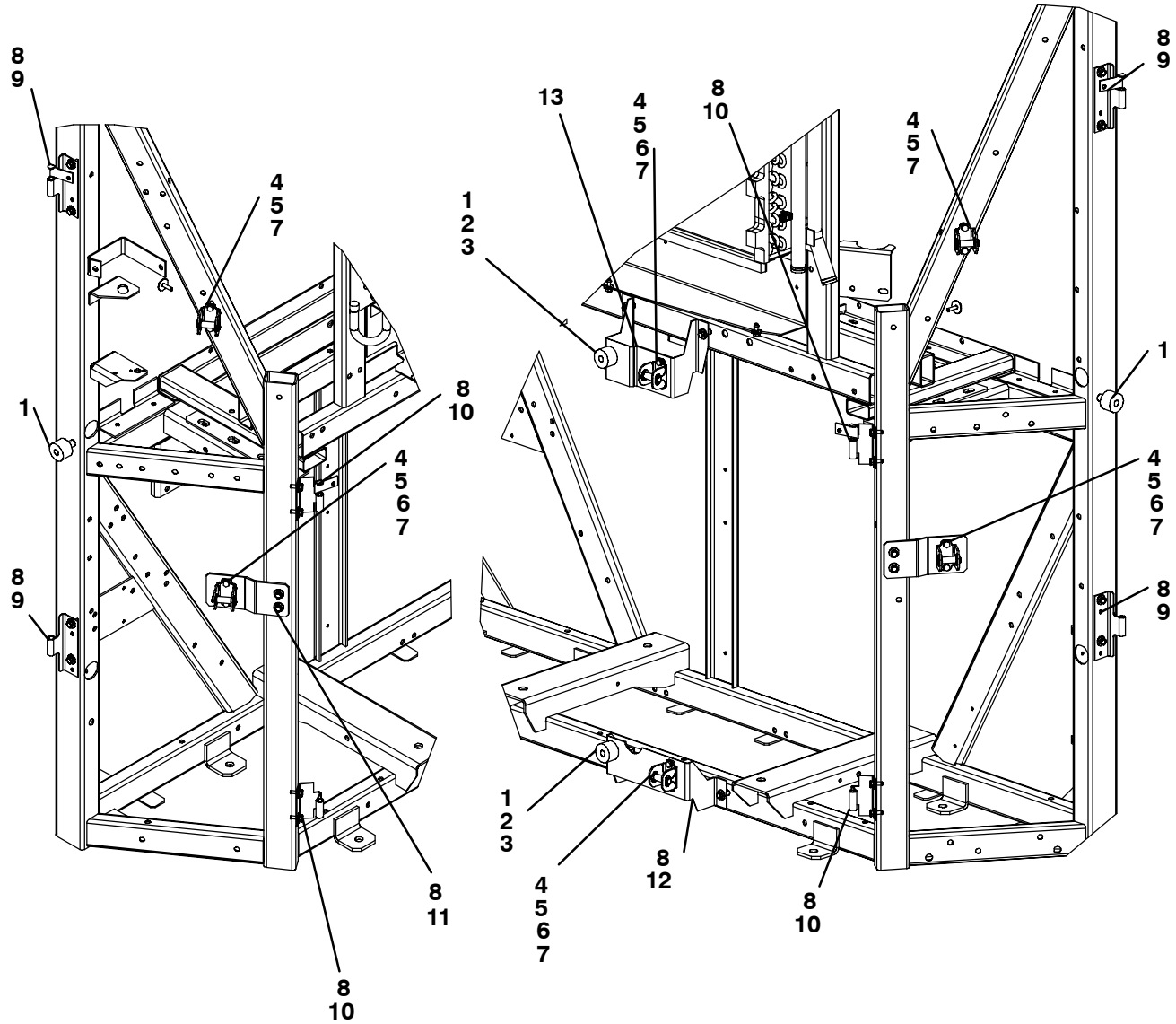

3.1 SKINS - HINGES

Item	Part Number	Description	Qty
1	58-04194-00	BUMPER, DOORS, BLACK MOLDED	4
2	34-00361-12	NUT, SELF LOCK, 5/16-18	2
3	34-00588-12	WASHER, PLAIN, 5/16"	4
4	34-00300-06	SCREW, CAP HXHD, 1/4-20 X .75	12
5	34-00368-11	WASHER, LOCK, 1/4"	12
6	34-06051-06	RIVNUT, 1/4-20	8
7	44-00441-00	STRIKE PIN ASSEMBLY, FLOATING	6
8	34-01294-06	SCREW, CAPT WASH, 1/4-20 X .75	23
9	44-00439-00	HINGE, SIDE DOORS, SST	4
10	44-00440-00	HINGE, FRONT DOORS, SST	4
11	68-15130-00	BRACKET, LOWER SIDE DOOR LATCHES	2
12	68-15124-00	BRACKET, LOWER FRONT DOOR LATCH	1
13	68-15125-00	BRACKET, UPPER FRONT DOOR LATCH	1

3.2 SKINS - ROADSIDE AND CURBSIDE OUTER DOORS - ROADSIDE SHOWN

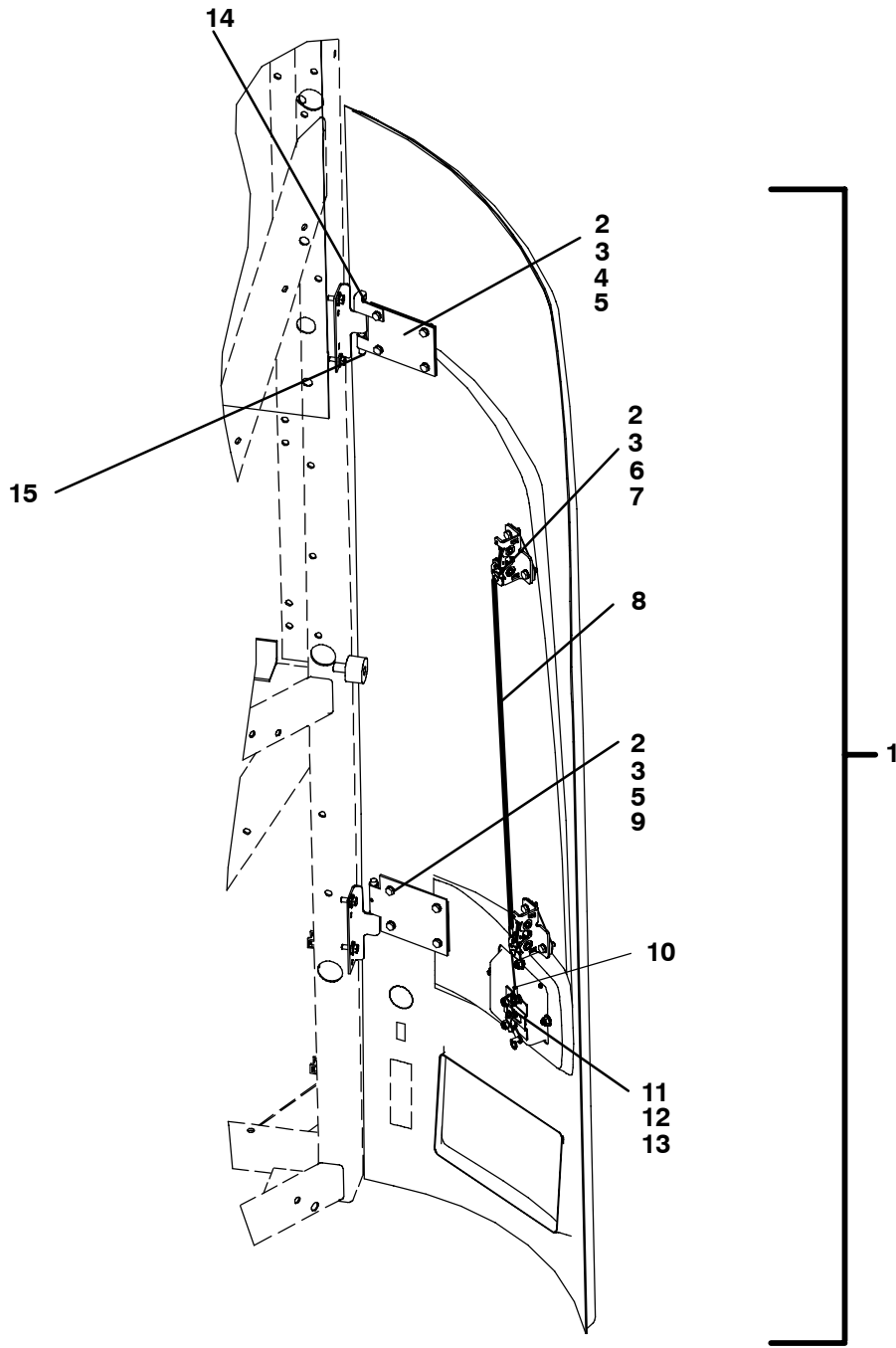

INSIDE OF ROADSIDE OUTER DOOR

3.2 SKINS - ROADSIDE AND CURBSIDE OUTER DOORS - ROADSIDE SHOWN

Item	Part Number	Description	Qty
1	58-04744-00	DOOR, CURBSIDE, OUTER, BLACK HANDLE - INCLUDES:	1
	58-04744-01	DOOR, CURBSIDE, OUTER, WITH FRESH AIR, BLACK HANDLE - INCLUDES:	1
	58-04744-02	DOOR, CURBSIDE, OUTER, BLACK HANDLE W/LOCK - INCLUDES:	1
	58-04744-03	DOOR, CURBSIDE, OUTER, BLACK HANDLE, AFAX, W/LOCK - INCLUDES:	1
	58-04744-04	DOOR, CURBSIDE, OUTER, CHROME HANDLE - INCLUDES:	1
	58-04741-00	DOOR, ROADSIDE, OUTER, BLACK HANDLE - INCLUDES:	1
	58-04741-01	DOOR, ROADSIDE, OUTER, BLACK HANDLE W/LOCK - INCLUDES:	1
	58-04741-02	DOOR, ROADSIDE, OUTER, CHROME HANDLE - INCLUDES:	1
2	34-00655-06	SCREW, CAP HXHD, 1/4-20 X .75	12
3	34-00663-11	WASHER, LOCK, 1/4"	12
4	44-01161-00	HINGE, UPPER, SST	1
5	86-02924-00	PLATE ASSEMBLY, NUT, HINGES	2
6	44-00442-00	LATCH, ROTARY	2
7	86-04615-00	PLATE ASSEMBLY, NUT, LATCHES	2
8	79-01935-01	CABLE ASSEMBLY, UPPER	1
9	44-01152-01	HINGE, LOWER, SST, CURBSIDE ONLY	1
	44-01152-00	HINGE, LOWER, SST, ROADSIDE ONLY	1
10	79-01935-00	CABLE ASSEMBLY, LOWER, CURBSIDE ONLY	1
	79-01935-02	CABLE ASSEMBLY, LOWER, ROADSIDE ONLY	1
11	34-01184-06	NUT, LOCK, M6	4
12	34-00829-11	WASHER, PLAIN, 1/4"	4
13	44-00443-00	ACTUATOR, PADDLE, BLACK, ROADSIDE ONLY	1
	44-00443-01	ACTUATOR, PADDLE, BLACK, CURBSIDE ONLY	1
	44-00443-02	ACTUATOR, PADDLE, CHROME, ROADSIDE ONLY	1
	44-00443-03	ACTUATOR, PADDLE, CHROME, CURBSIDE ONLY	1
	44-00443-04	ACTUATOR, PADDLE, BLACK W/LOCK, ROADSIDE ONLY	1
	44-00443-06	ACTUATOR, PADDLE, BLACK W/LOCK, CURBSIDE ONLY	1
14	68-07902-01	TAB, LOCKING, CURBSIDE ONLY	1
	68-07902-00	TAB, LOCKING, ROADSIDE ONLY	1
15	34-01284-00	PIN, 3/8" CLEVIS	2

3.3 SKINS - ROADSIDE AND CURBSIDE FRONT DOORS - ROADSIDE SHOWN

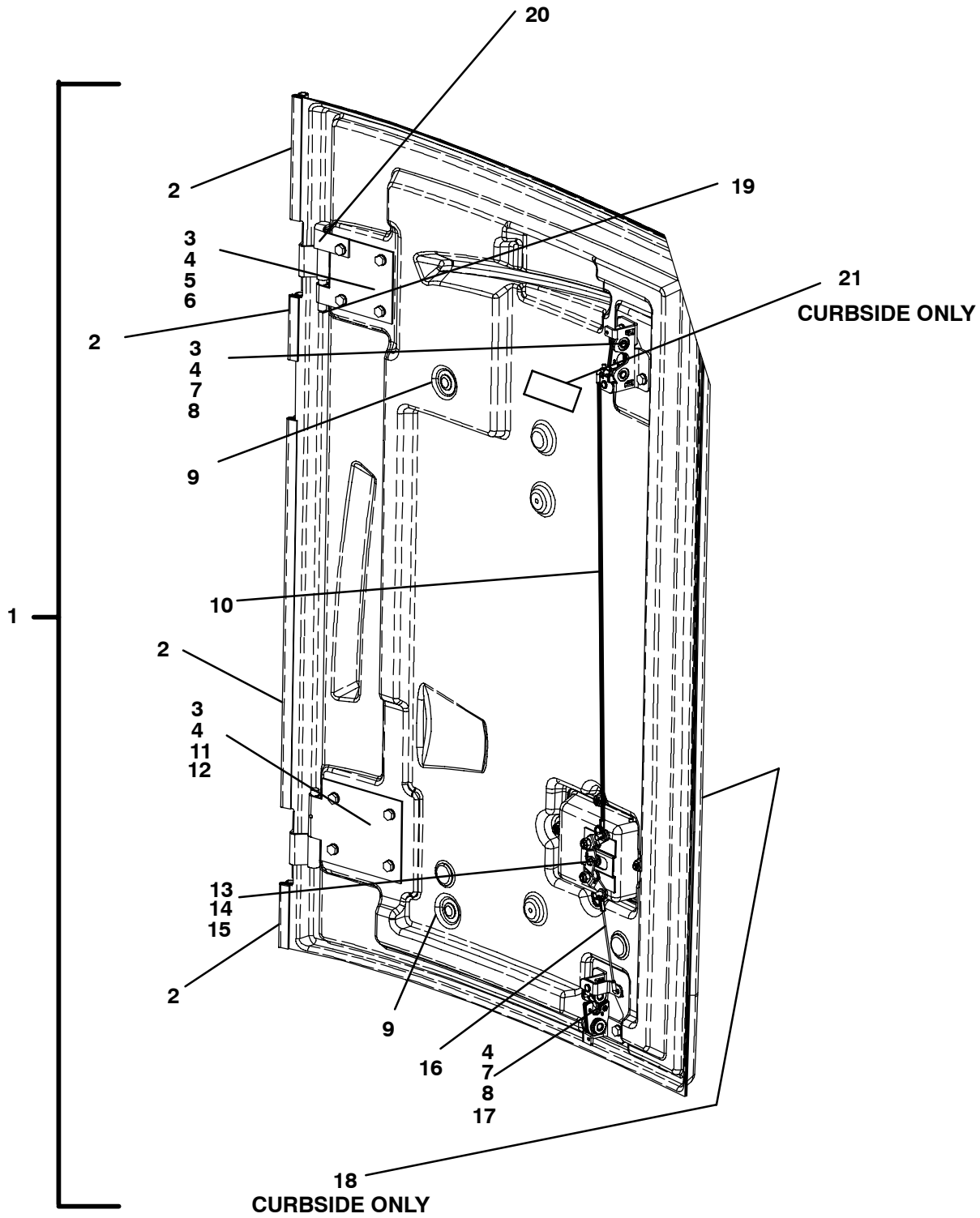

3.3 SKINS - ROADSIDE AND CURBSIDE FRONT DOORS - ROADSIDE SHOWN

Item	Part Number	Description	Qty
1	58-04742-00	DOOR, ROADSIDE, FRONT, BLACK HANDLE - INCLUDES:	1
	58-04742-01	DOOR, ROADSIDE, FRONT, BLACK HANDLE W/LOCK - INCLUDES:	1
	58-04742-02	DOOR, ROADSIDE, FRONT, CHROME HANDLE - INCLUDES:	1
	58-04743-00	DOOR, CURBSIDE, FRONT - INCLUDES:	1
2	42-00264-11	SEAL, TRIM, BLACK (SOLD PER FOOT)	A / R
3	34-00655-06	SCREW, CAP HXHD, 1/4-20 X .75	8 / 10
4	34-00663-11	WASHER, LOCK, 1/4"	8 / 12
5	44-00445-00	HINGE, UPPER, SST	1
6	86-04614-00	PLATE ASSEMBLY, NUT, UPPER HINGE	1
7	44-00442-00	LATCH, ROTARY, ROADSIDE ONLY	2
8	86-04615-00	PLATE ASSEMBLY, NUT, LATCH, ROADSIDE ONLY	2
9	58-04739-00	PLUG, RACHET	2
10	79-01935-03	CABLE ASSEMBLY, UPPER	1
11	44-01152-00	HINGE, LOWER, SST, ROADSIDE ONLY	1
	44-01152-01	HINGE, LOWER, SST, CURBSIDE ONLY	1
12	86-02924-00	PLATE ASSEMBLY, NUT, LOWER HINGE	1
13	34-01184-06	NUT, LOCK, M6, ROADSIDE ONLY	4
14	34-00829-11	WASHER, PLAIN, 1/4", ROADSIDE ONLY	4
15	44-00443-00	ACTUATOR, PADDLE, BLACK, ROADSIDE ONLY	1
	44-00443-02	ACTUATOR, PADDLE, CHROME, ROADSIDE ONLY	1
	44-00443-04	ACTUATOR, PADDLE, BLACK W/LOCK, ROADSIDE ONLY	1
16	79-01935-04	CABLE ASSEMBLY, LOWER	1
17	34-00655-04	SCREW, CAP HXHD, 1/4-20 X .50, ROADSIDE ONLY	2
18	42-00264-12	SEAL, TRIM, BLACK (SOLD PER FOOT), CURBSIDE ONLY	A / R
19	34-01284-00	PIN, 3/8" CLEVIS	2
20	68-07902-01	TAB, LOCKING, CURBSIDE ONLY	1
	68-07902-00	TAB, LOCKING, ROADSIDE ONLY	1
21	62-10784-00	DECAL, SERVICE, PRIMING CURBSIDE ONLY STANDARD FILTER	1
	62-04007-00	DECAL, FUEL PRIMING CURBSIDE ONLY DAVCO FILTER	1

3.4 SKINS - CONDENSER GRILL

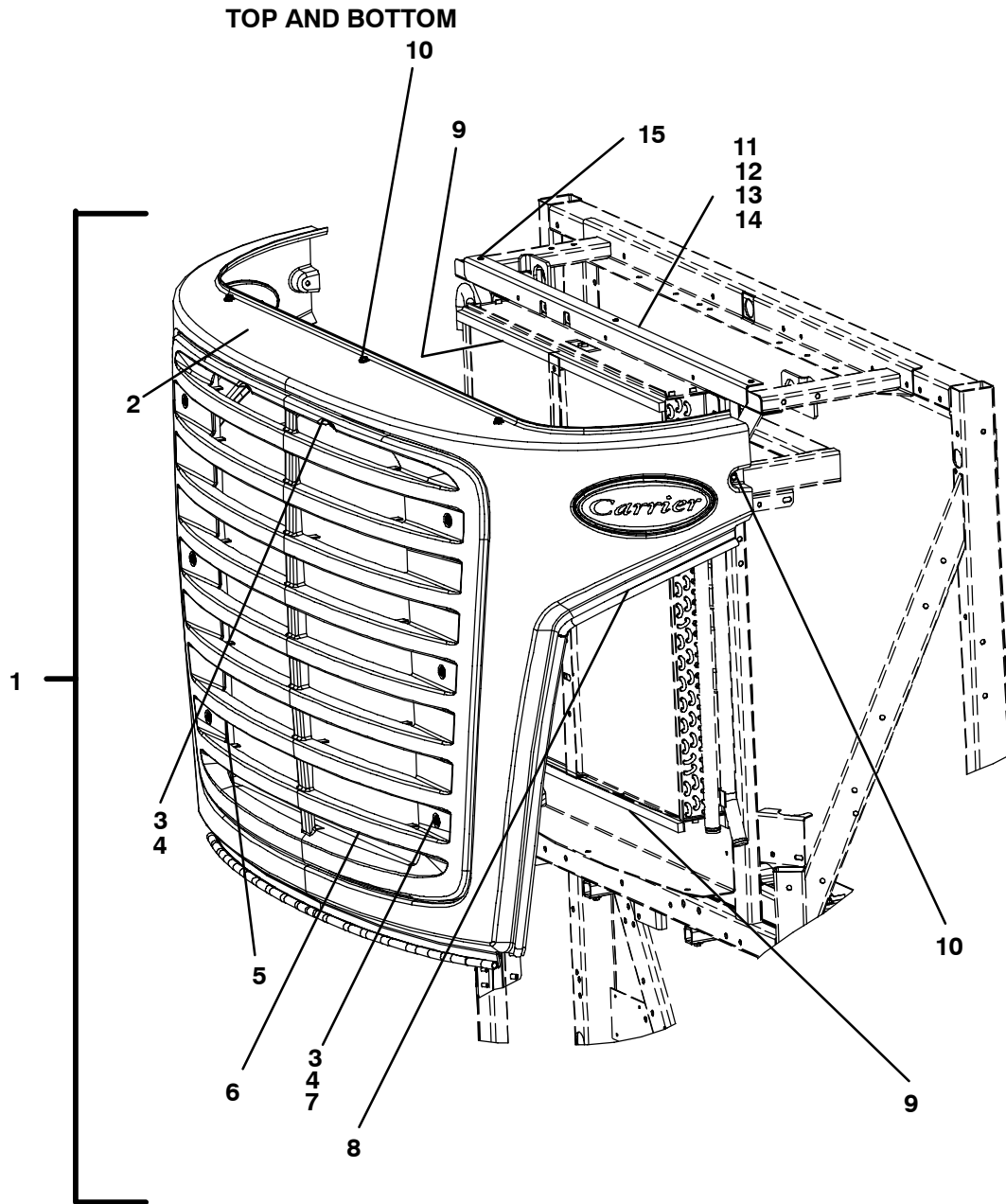

3.4 SKINS - CONDENSER GRILL

Item	Part Number	Description	Qty
1	58-04738-00	GRILL/SURROUND ASSEMBLY, FRONT, BLACK - INCLUDES:	1
	58-04738-01	GRILL/SURROUND ASSEMBLY, FRONT, CHROME - INCLUDES:	1
2	58-04737-00	SURROUND, GRILL, BLACK	1
3	34-06310-00	NUT, RETAINER, M6, U-CLIP	8
4	34-06311-08	SCREW, TORX HD, M6 X 1" L, BLACK GRILL ONLY	8
	34-06312-08	SCREW, TORX HD, M6 X 1" L, CHROME GRILL ONLY	8
5	42-00688-00	GASKET, GRILL, VERTICAL	2
6	58-04736-00	GRILL, FRONT, BLACK	1
	58-04736-01	GRILL, FRONT, CHROME	1
7	58-04755-00	WASHER / SPACER, RUBBER, .125" ID	6
8	42-00264-16	SEAL TRIM, BLACK (SOLD PER FOOT)	A / R
9	42-00690-00	GASKET, FRONT GRILL, HORIZONTAL	2
10	34-01294-06	SCREW, CAPT WASH, 1/4-20 X .75	8
11	68-15314-00	ANGLE, FRONT GRILL MOUNTING	1
12	34-00663-11	WASHER, LOCK, 1/4 - SST	3
13	34-00655-08	SCREW, CAP HEX HEAD, 1/4-20 X 1.00 LG. - SST	3
14	34-00662-11	WASHER, FLAT, 1/4 - SST	3
15	34-06051-36	RIVNUT, 1/4-20, (.027 / .165)	3

3.5 SKINS - UPPER AND LOWER BACK PANELS

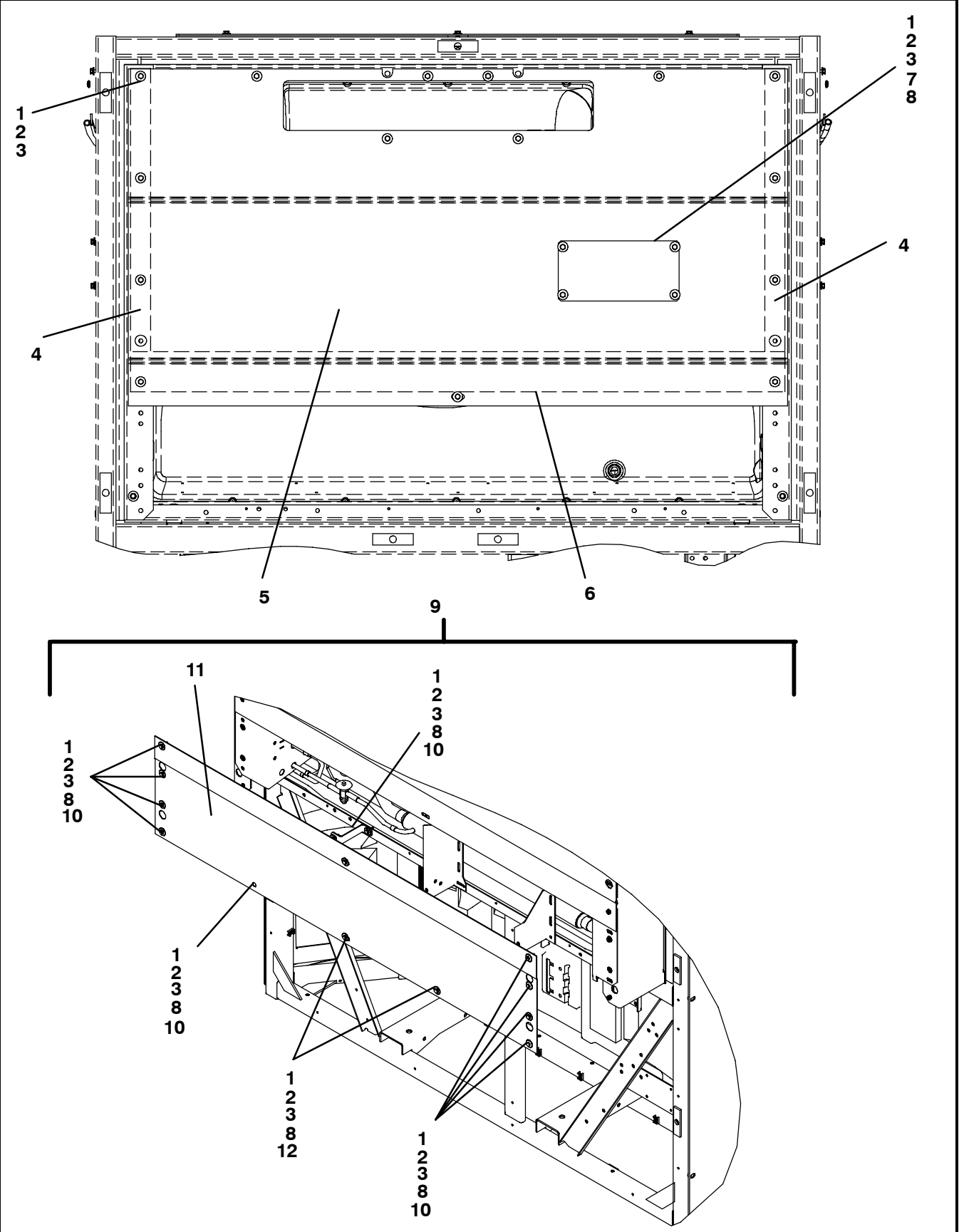

3.5 SKINS - UPPER AND LOWER BACK PANELS

Item	Part Number	Description	Qty
1	34-00662-20	WASHER, PLAIN, .281 ID	19
2	34-00663-11	WASHER, LOCK, 1/4 SPRING	19
3	34-00655-08	SCREW, CAP HXHD, 1/4-20 X 1.00	19
4	42-00504-00	GASKET, BACK PANEL, VERTICAL	2
5	68-07921-00	PANEL, BACK, EVAPORATOR	1
6	42-00392-00	GASKET, BACK PANEL, HORIZONTAL	1
7	68-07236-00	PANEL, ACCESS, EVAPORATOR BACK PANEL	1
8	34-06051-36	RIVNUT, 1/4-20, (.027 /.165)	4
9	76-02001-00	LOWER BACK PANEL KIT - INCLUDES:	1
10	68-12666-00	BRACKET, LOWER PANEL SUPPORT	1
11	68-08076-00	BACK PANEL ASSEMBLY, LOWER	1
2	34-00663-11	WASHER, LOCK, 1/4"	10
3	34-00655-08	SCREW, CAP HXHD, 1/4-20 X 1.00" L	10
1	34-00662-20	WASHER, PLAIN, .281" ID	10
8	34-06051-36	RIVNUT, 1/4-20, (.027/.165") GRIP RANGE	8
12	34-06051-37	RIVNUT, 1/4-20, (.165/.260") GRIP RANGE	2

4 REFRIGERATION

4.1 REFRIGERATION - AIR SWITCH AND HARDWARE

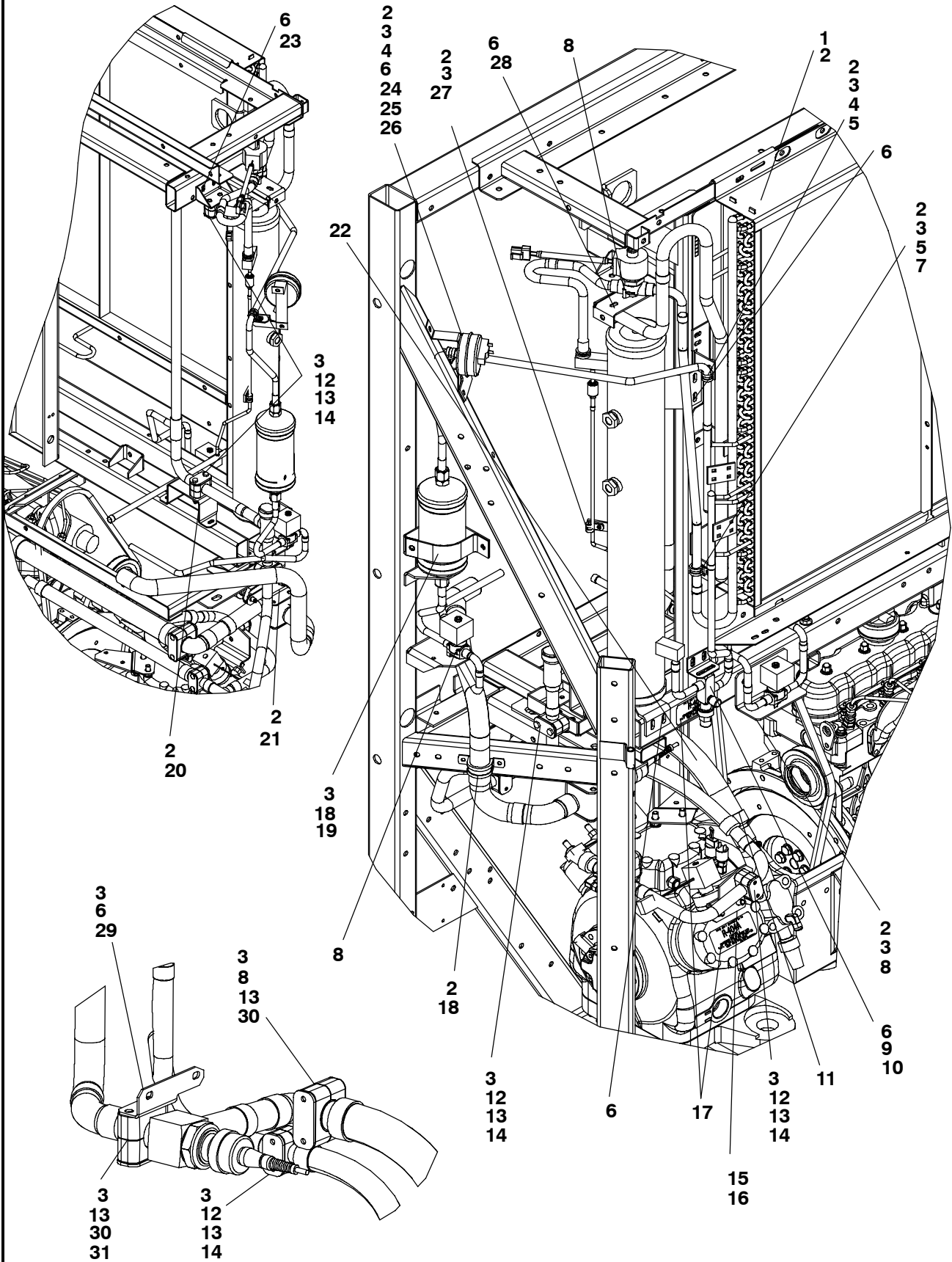

4.1 REFRIGERATION - AIR SWITCH AND HARDWARE

Item	Part Number	Description	Qty
1	08-00306-00	COIL, CONDENSER / RADIATOR - X2 2500 A/R ONLY	1
	08-00305-00	COIL, CONDENSER / RADIATOR - X2 2100 A/R ONLY	
2	34-01294-06	SCREW, CAPT. WASH, 1/4-20 X .75	27
3	34-06051-06	RIVNUT, 1/4-20	30
4	34-00373-05	CLAMP, CUSHION, .50 DIAMETER	2
5	68-13651-00	BRACKET, COND TUBE SUPPORT	2
6	34-01294-08	SCREW, CAPT. WASH, 1/4-20 X 1.00	11
7	34-00373-07	CLAMP, CUSHION, .62 DIAMETER	1
8	34-00996-08	SCREW, HEX WASHERHEAD, 1#8-32 X .50 LG	6
9	68-06986-00	BRACKET, KING VALVE	1
10	34-00918-04	SCREW, HEX WASHERHEAD, 1/4-20 X .50 LG.	1
11	42-00237-52	INSULATION, TUBE, 1-3/8 NOM X 5FT LG.	A / R
12	44-00285-60	CLAMP, TUBE, 7/8 O.D.	4
13	34-00368-11	WASHER, LOCK, 1/4	14
14	34-00300-18	SCREW, CAP HXHD, 1/4-20 X 2.25	10
15	34-00361-13	NUT, SELF LOCK, 3/8-16	2
16	68-14439-00	BRACKET, DISC LINE / COMP HEAD	1
17	62-03797-11	LABEL, R-404A / COMPRESSOR OIL	2
18	44-01028-13	CLAMP, TUBE, 1.38 DIAMETER	1
19	68-11547-00	BRACKET, FILTER-DRIER	1
20	86-04257-01	BRACKET ASSEMBLY, DISCHARGE CHECK VALVE OUTLET	1
21	86-04565-00	BRACKET ASSEMBLY, DISCHARGE CHECK VALVE INLET	1
22	42-00237-54	INSULATION, TUBE, 1-5/8 NOM X 5FT LG.	A / R
23	86-04595-00	BRACKET ASSEMBLY, UPPER DISCHARGE LINE SUPPORT	1
24	12-00303-00	SWITCH, AIR PRESSURE, WITH BRACKET	1
25	68-07673-00	BRACKET, LIQUID LINE SUPPORT	1
26	22-01100-00	TUBING, CLEAR, AIR SWITCH, 25FT ROLL	1
27	44-01134-04	CLAMP, TUBE, .25 I.D., CUSHIONED	1
28	86-02803-02	BRACKET, SV1	1
29	68-13157-00	BRACKET, SMV VALVE	1
30	34-00300-24	SCREW, CAP HEX HEAD, 1/4-20 X 3.00 LG.	4
31	44-00285-20	CLAMP, TUBE, 1 3/8 O.D., 3 PCS	1
32	44-00285-22	CLAMP, TUBE, 1 1/2 O.D., 3 PCS	1

4.2 REFRIGERATION - TUBING

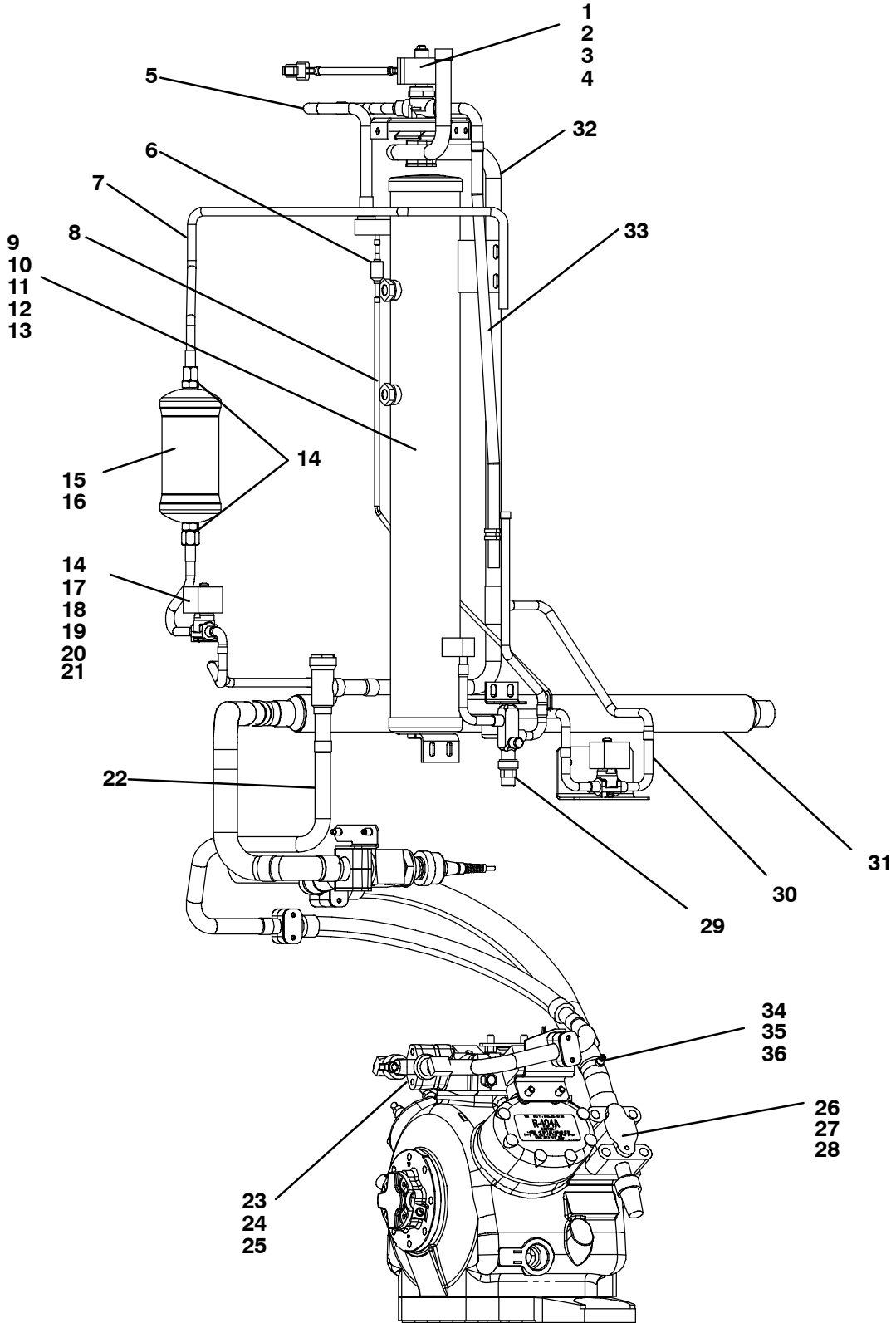

4.2 REFRIGERATION - TUBING

Item	Part Number	Description	Qty
1	14-00324-01	VALVE, SOLENOID, WITH STUB-OUTS, SV1 - INCLUDES:	1
2	14-01114-20	COIL (VDC) WITH CONNECTOR - INCLUDES:	1
3	22-50078-01SV	CONNECTOR, 2-WIRE (MATES W/ 22-50078-02SV)	1
4	14-01114-51	REPAIR KIT, SOLENOID VALVE	1
5	56-06942-05	TUBE, 5/8" O.D., SV1 TO RECEIVER INLET	1
6	14-00199-00	VALVE, CHECK, RECEIVER PRESSURIZATION	1
7	56-08089-00	TUBE, 1/2 O.D. DRIER INLET	1
8	56-08092-00	TUBE, 1/4 O.D. RECEIVER PRESSURE CHECK VALVE	1
9	65-00182-03	RECEIVER TANK - INCLUDES:	1
10	65-00168-24	SIGHTGLASS WITH O-RING - INCLUDES:	2
11	65-00168-22	O-RING, SIGHTGLASS	1
12	65-01085-21	FUSIBLE PLUG	1
13	65-01085-22	O-RING, FUSIBLE PLUG	1
14	40-60029-02	FITTING, MACHINED 1/2" FLARE, WITH NUT	1
15	14-00209-00	FILTER-DRIER, 1/2 SAE FLARE - INCLUDES:	1
16	14-00209-20	O-RING, DRIER	2
17	14-00348-05	VALVE/TUBE ASSY, W/ COIL & STUB-OUTS, SV2 - INCLUDES:	1
18	14-00350-03	VALVE, SOLENOID, LESS COIL	1
19	22-02579-00	COIL, SOLENOID VALVE - INCLUDES:	1
20	22-50078-02SV	CONNECTOR, 2-WIRE (MATES WITH 22-50078-01SV)	1
14	40-60029-02	FITTING, MACHINED 1/2" FLARE, WITH NUT	1
21	14-00150-51	REPAIR KIT, SOLENOID VALVE	1
22	-	DISCHARGE TUBE ASSEMBLY - REFER TO SECTION 4.2.1	1
23	17-40013-00	GASKET, CAP SCREW	2
24	34-00302-18	SCREW, CAP HEX HEAD, 5/16-18 X 2.25" LG.	2
25	-	LOWER DISCHARGE ASSEMBLY - REFER TO SECTION 4.2.1	1
26	14-00308-00	VALVE ASSEMBLY, SUCTION SERVICE - REFER TO SECTION 4.2.4	1
27	34-00308-20	SCREW, CAP HEX HEAD, 1/2-13 X 2.50 LG.	4
28	34-06038-00	WASHER, GASKET, .561 I.D. X .75 O.D.	4
29	14-00310-01	KING VALVE - REFER TO SECTION 4.2.3	1
30	14-00348-04	VALVE, SV4 - REFER TO SECTION 4.2.2	1
31	81-01653-01	HEAT EXCH. ASSEMBLY, X2 2500 A/R - REFER TO SECTION 5.5	1
	81-01653-02	HEAT EXCH. ASSEMBLY, X2 2100 A/R - REFER TO SECTION 5.5	1
32	-	MIDDLE DISCHARGE LINE ASSEMBLY - REFER TO SECTION 4.2.1	1
33	56-08180-00	TUBE, BENT, 5/8" OD, SV1 INLET	1
34	12-00352-03SV	TRANSDUCER SUCTION PRESS - INCLUDES:	1
35	22-04036-00	PATCH CABLE, SUCTION TRANSDUCER - INCLUDES:	1
36	22-50098-60	CONNECTOR, 3-WIRE (MATES WITH 22-50098-59)	1

4.2.1 REFRIGERATION - DISCHARGE LINE

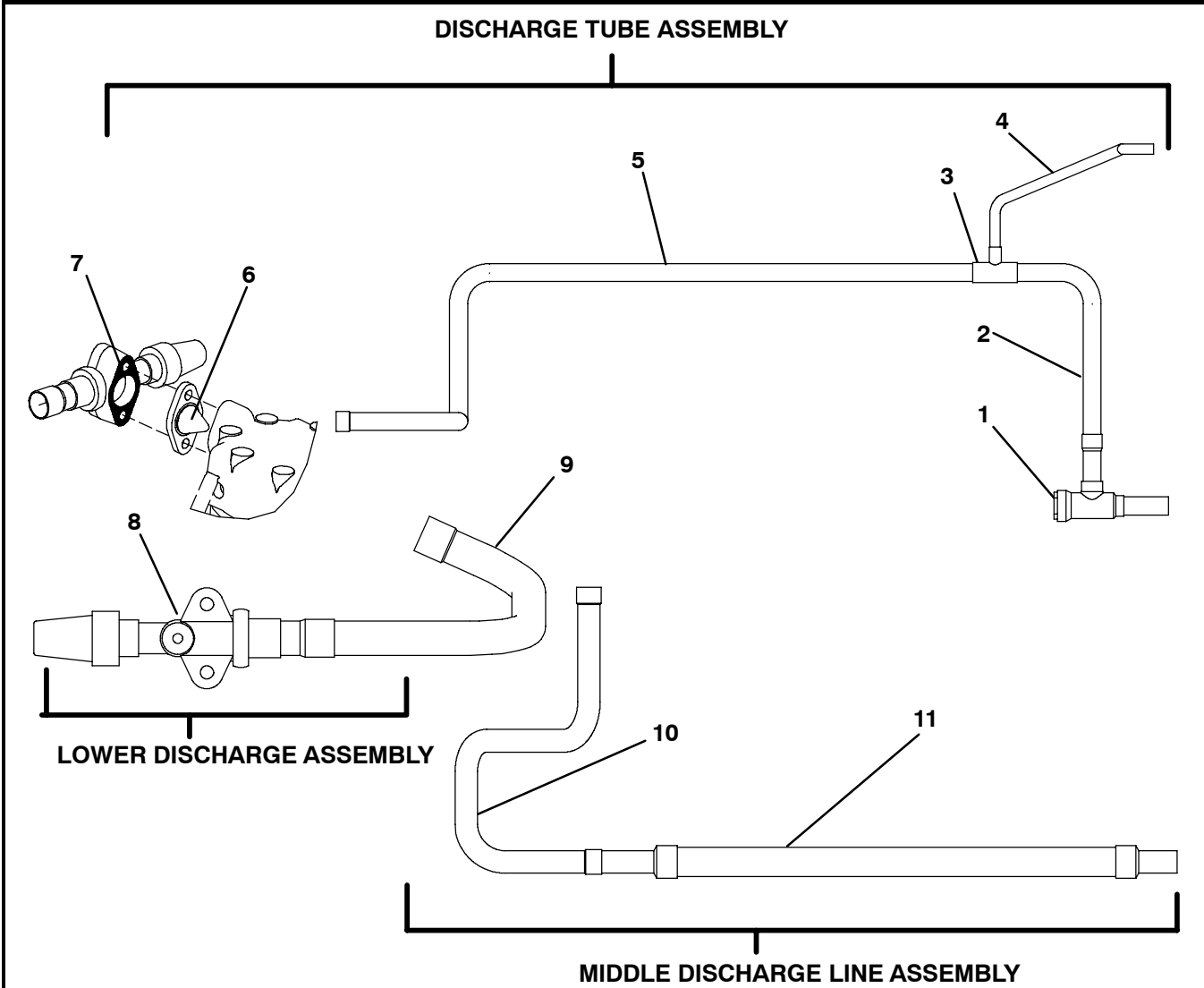

Item	Part Number	Description	Qty
1	14-00331-00	VALVE, CHECK, DISCHARGE, 90°	1
2	56-08087-01	TUBE, BENT, 7/8" O.D., DISC, CHECK VALVE OUTLET	1
3	40-00169-08	TEE, REDUCING, 7/8 X 7/8 X 1/2	1
4	56-08579-00	TUBE, BENT, 1/2" O.D, SV 4 INLET	1
5	56-08433-00	TUBE, BENT, 7/8" O.D., COND. INLET	1
6	14-00322-00	STRAINER ASSEMBLY, DISCHARGE	1
7	17-44138-00	GASKET, DISCHARGE SERVICE VALVE	1
8	14-00309-03	VALVE, SERVICE, DISCHARGE, WITH 7/8" STUB-OUTS	1
9	56-08161-00	TUBE, BENT, 7/8" O.D, DISCHARGE SERV VALVE TO VIBRASORBER	1
10	56-08434-00	TUBE, BENT, 7/8" O.D., DISCH. VIBRASORBER TO CHECK VALVE	1
11	73-00201-00	VIBRASORBER, DISCHARGE	1

4.2.2 REFRIGERATION - HOT GAS LINE

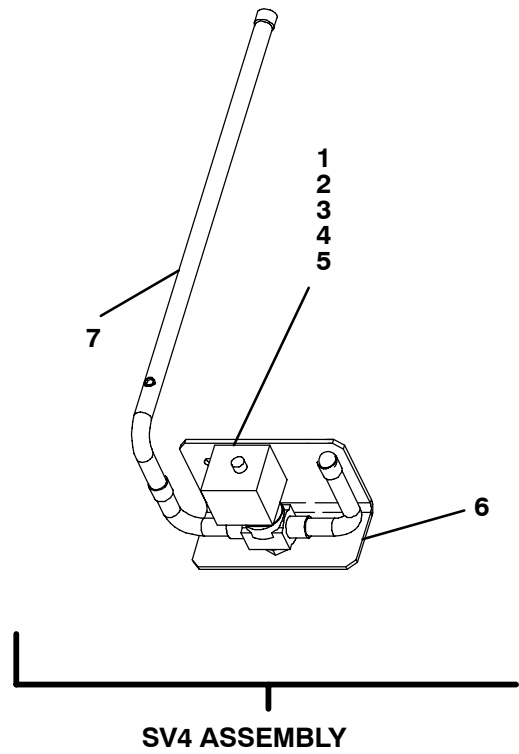

1	14-00348-04	VALVE / TUBE ASSY, WITH COIL & STUB-OUTS, SV4 - INCLUDES:	1
2	14-00350-03	VALVE, SOLENOID, LESS COIL	1
3	22-02579-00	COIL, SOLENOID VALVE - INCLUDES:	1
4	22-50078-02SV	CONNECTOR, 2-WIRE (MATES WITH 22-50078-01SV)	1
5	14-00150-51	REPAIR KIT, SOLENOID VALVE	1
6	68-14256-00	BRACKET, SV4	1
7	56-08061-00	TUBE, BENT, 1/2" O.D., SV 4 OUTLET	1

4.2.3 REFRIGERATION - KING VALVE AND SV2 VALVE

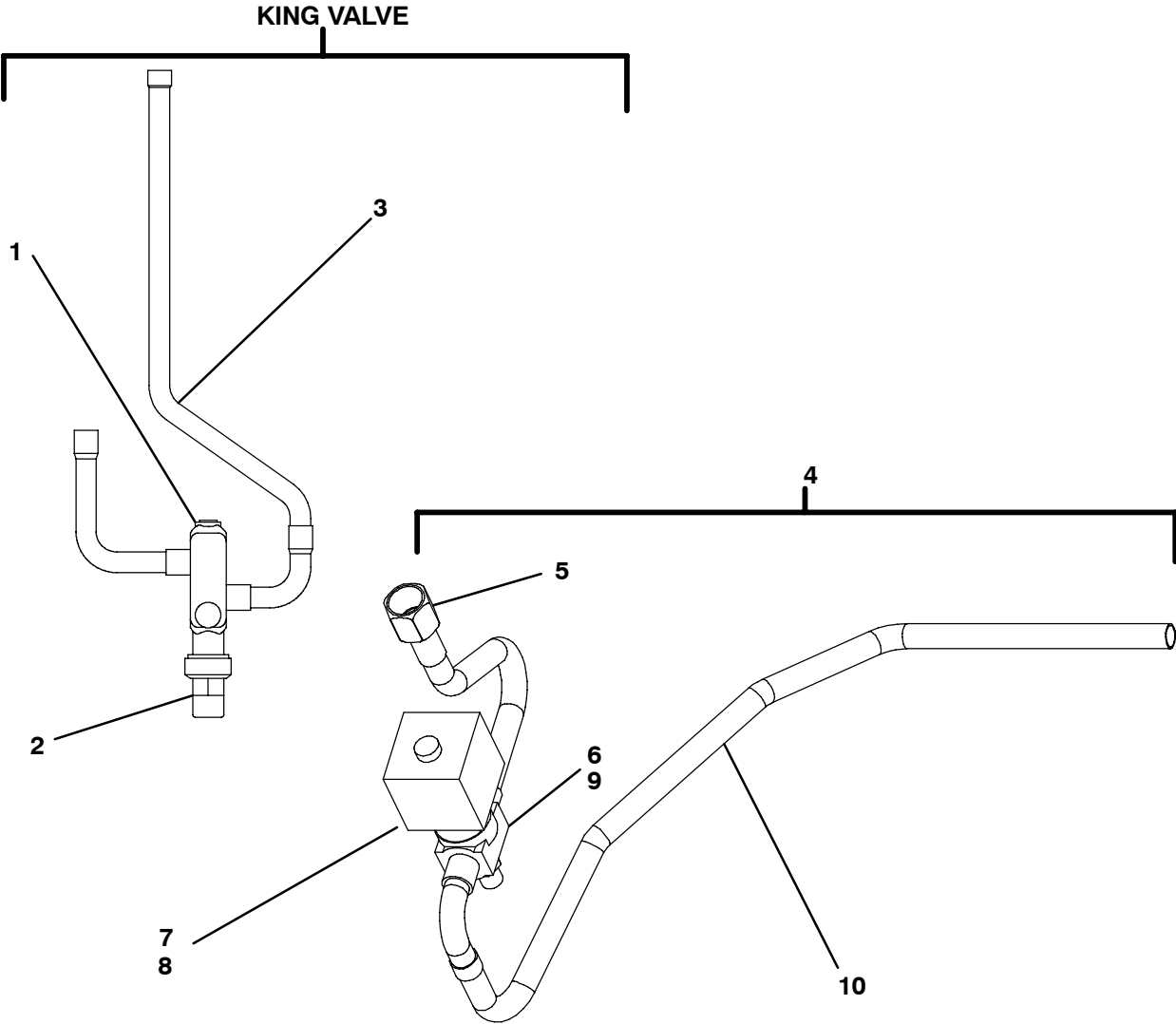

Item	Part Number	Description	Qty
1	14-00310-01	VALVE, KING, WITH 1/2" STUB-OUTS - INCLUDES:	1
2	40-00501-50	CAP, KING VALVE	1
3	56-08080-00	TUBE, BENT, 1/2" O.D, KING VALVE OUTLET	1
4	14-00348-05	VALVE/TUBE ASSEMBLY W/COIL AND SUB-OUTS, SV2 - INCLUDES:	1
5	40-60029-02	FITTING, MACHINED 1/2" FLARE, WITH NUT	1
6	14-00350-03	VALVE, SOLENOID, LESS COIL	1
7	22-02579-00	COIL, SOLENOID VALVE - INCLUDES	1
8	22-50078-02SV	CONNECTOR, 2-WIRE (MATES WITH 22-50078-01SV)	1
9	14-00150-51	REPAIR KIT, SOLENOID VALVE	1
10	56-03757-00	TUBE, 1/2 OD SV2 TO LSHX	1

4.2.4 REFRIGERATION - SUCTION LINE

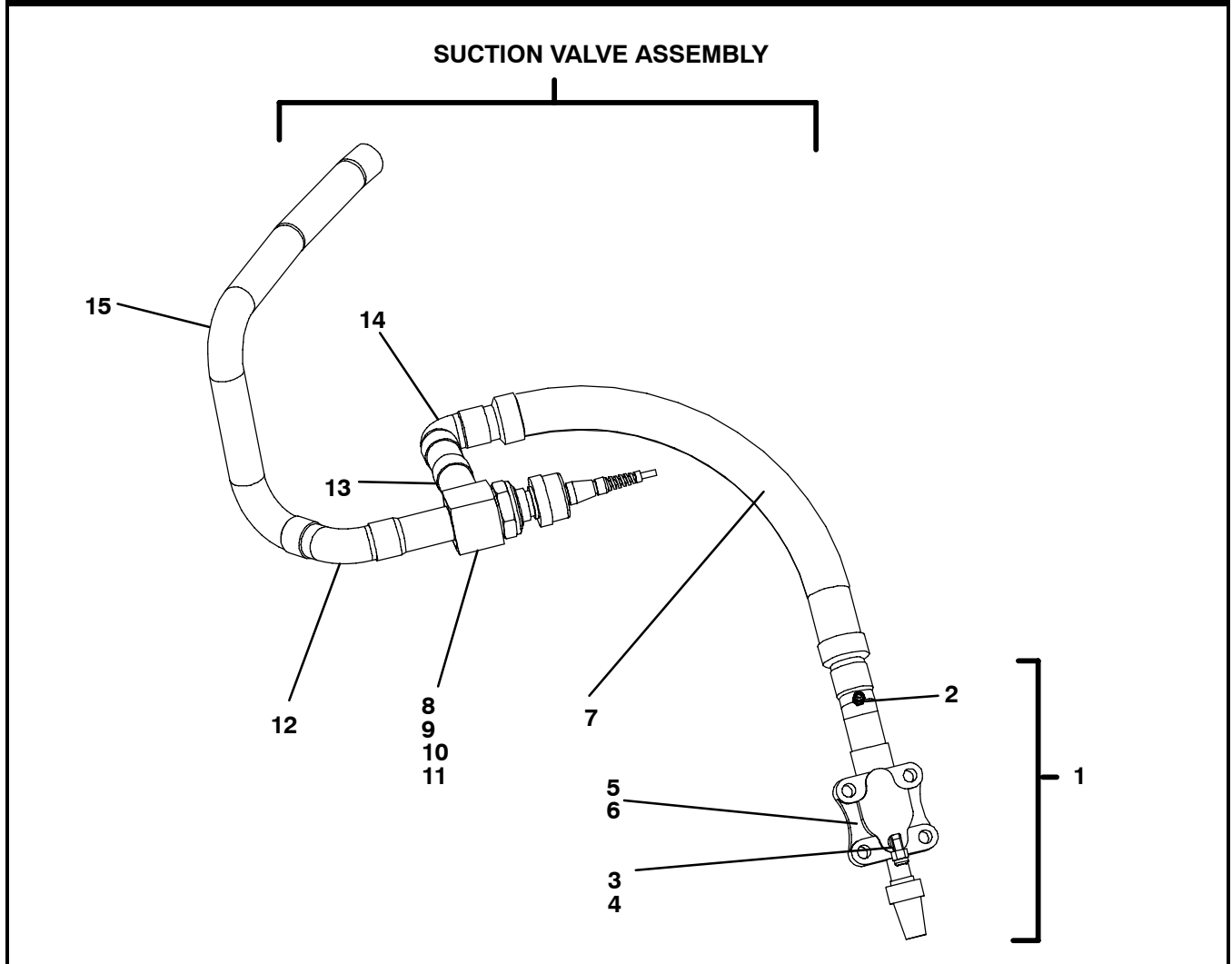

Item	Part Number	Description	Qty
1	14-00308-00	VALVE, SERVICE, SUCTION WITH 1-3/8" STUB-OUTS - INCLUDES:	1
2	40-01124-00	BODY, SCHRADER VALVE, WITH CORE & CAP	1
3	40-00102-04	ELBOW, 90° STREET 1/4 MFL X 1/4 MPT	1
4	40-00086-04	CAP, SEAL, 1/4 FEMALE FLARE	1
5	17-44141-00	GASKET, SUCTION SERVICE VALVE	1
6	58-00869-00	BAG, FELT, SUCTION FILTER SOCK	1
7	73-00328-10	VIBRASORBER, SUCTION, WITH COVER	1
8	14-00263-03	VALVE, SOLENOID, SMV - INCLUDES:	1
9	14-00263-20	PISTON / MOTOR ASSEMBLY	1
10	14-00263-22	CAP	1
11	22-02392-03SV	CONNECTOR, 4-PIN, MALE (MATES WITH 22-01585-04SV)	1
12	56-07605-00	TUBE, BENT, 55°, 1-3/8" O.D. SMV INLET	1
13	56-07257-03	TUBE, 1-3/8" O.D., SMV OUTLET	1
14	40-00071-11	ELBOW, 90° 1 3/8" X 1 3/8" ODS	1
15	56-08086-00	TUBE, BENT, 1-3/8" O.D, LSHX OUTLET TO SMV	1

5 EVAPORATOR ASSEMBLY

5.1 FRAME AND POD

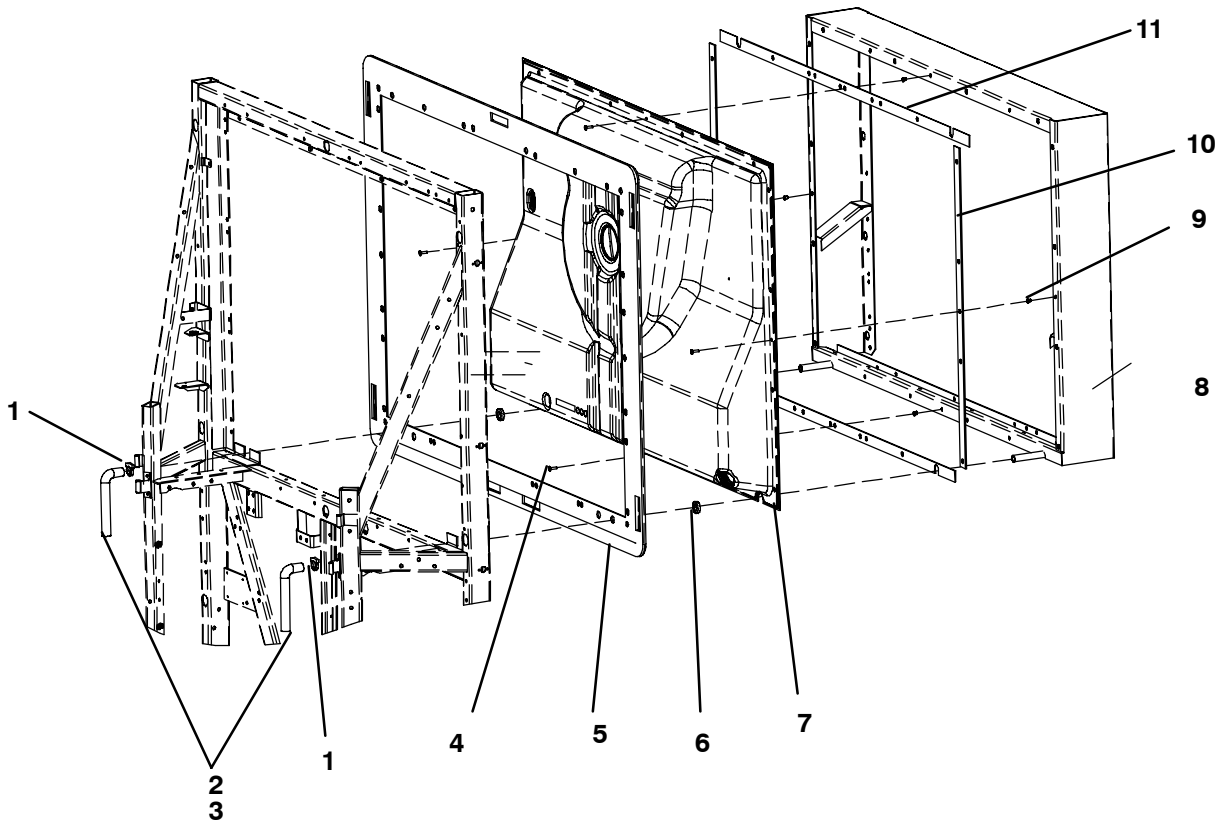

Item	Part Number	Description	Qty
1	58-00712-15	CLAMP, HOSE, .985 - 1.135 O.D.	2
2	58-01369-00	HOSE, DEFROST DRAIN, 84" L	2
3	58-00253-00	KAZOO, DRAIN HOSE FITTING	2
4	34-00960-16	SCREW, FLAT SOCKET HEAD, 1/4-20 X 1.00 - STEEL	4
5	58-01278-01	SEAL, UNIT TO TRAILER	1
6	42-00386-00	GASKET, DRAIN TUBE	2
7	58-04439-05	POD, EVAPORATOR	1
	58-04439-06	POD ASSEMBLY, EVAP, FRESH AIR (AFAX) UNITS ONLY	
8	86-04390-00	FRAME ASSEMBLY, EVAPORATOR	1
9	34-06051-36	RIVNUT, 1/4-20	4
10	42-00258-10	GASKET, EVAPORATOR FRAME, POD VERTICAL	2
11	42-00258-09	GASKET, EVAPORATOR FRAME, POD HORIZONTAL	2

5.2 EVAPORATOR - POD HARDWARE

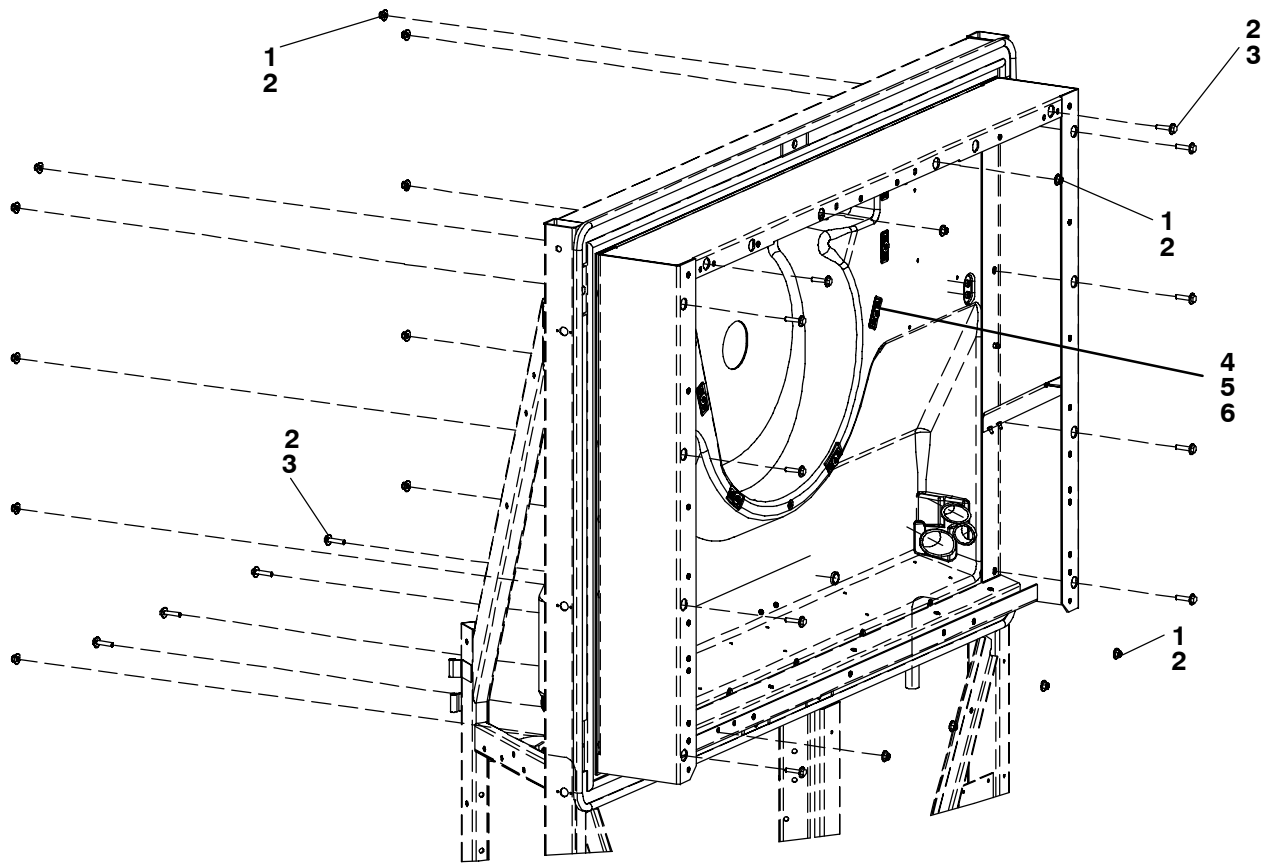

Item	Part Number	Description	Qty
1	34-00667-112	NUT, SELF LOCK, 5/16-18, SST	16
2	34-00662-12	WASHER, PLAIN, 5/16"	30
3	34-01236-12	SCREW, CAP HEX HEAD, 5/16-18 X 1.50 LG., SST	14
4	68-13717-00	PLATE, NOZZLE TO POD MOUNTING	8
5	34-00829-13	WASHER, PLAIN, 3/8"	16
6	34-06051-37	RIVNUT, 1/4-20	8

5.3 EVAPORATOR - BLOWER ASSEMBLY AND EVAPORATOR COIL

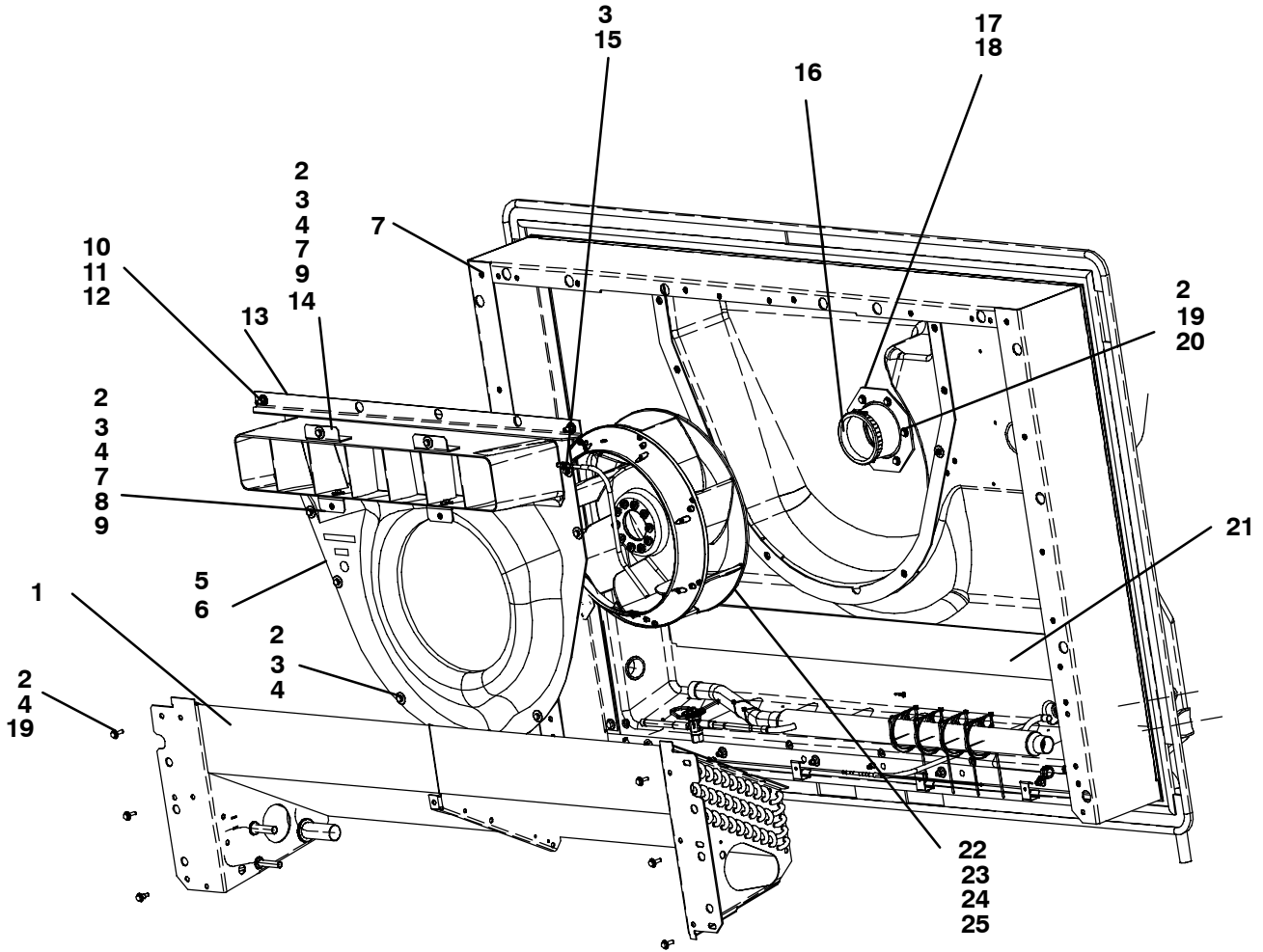

5.3 EVAPORATOR - BLOWER ASSEMBLY AND EVAPORATOR COIL

Item	Part Number	Description	Qty
1	08-00225-02	COIL, EVAPORATOR	1
2	34-00663-11	WASHER, LOCK, 1/4 - SST	30
3	34-00662-20	WASHER, FLAT, 9/32 I.D. SPECIAL - SST	16
4	34-00655-08	SCREW, CAP HEX HEAD, 1/4-20 X 1.00 LG. - SST	25
5	58-04703-00	COVER, NOZZLE - INCLUDES:	1
6	42-00506-01	GASKET, NOZZLE COVER	1
7	34-06051-36	RIVNUT, 1/4-20	A / R
8	68-13797-00	ANGLE, NOZZLE TO SKIN, BOTTOM	2
9	34-00665-10	SCREW, CAP HEX HEAD, 1/4-20 X 1.25 LG. - SST	2
10	34-00662-12	WASHER, PLAIN, 5/16 - SST	2
11	34-00663-12	WASHER, LOCK, 5/16 SPRING	2
12	34-00666-12	NUT, HEX, 5/16-18	2
13	68-13636-00	ANGLE, NOZZLE MOUNTING, TOP	1
14	68-13796-00	ANGLE, NOZZLE/SKIN, TOP	2
15	34-00373-51	CLAMP, .50 DIAMETER	1
16	44-01140-06	CLAMP, HOSE, 3.75 - 4.50 - SST	1
17	42-00372-00	SEAL/BOOT, FAN SHAFT	1
18	68-07818-00	RING, FAN SHAFT SEAL	1
19	34-00662-11	WASHER, FLAT, 1/4 - SST	12
20	34-00655-06	SCREW, CAP HXHD, 1/4-20 X .75	6
21	42-00258-00	GASKET, REAR WALL / POD	1
22	38-00556-20SV	BLOWER WHEEL, CENTRIFUGAL - INCLUDES:	1
23	04-00122-30SV	BUSHING, SPLIT TAPER - INCLUDES:	1
24	34-00775-10	SCREW, CAP HEX HEAD, 1/4-20 X 1.25 LG.	2
25	34-00368-11	WASHER, LOCK, 1/4 - SST	2

5.4 EVAPORATOR - HARDWARE

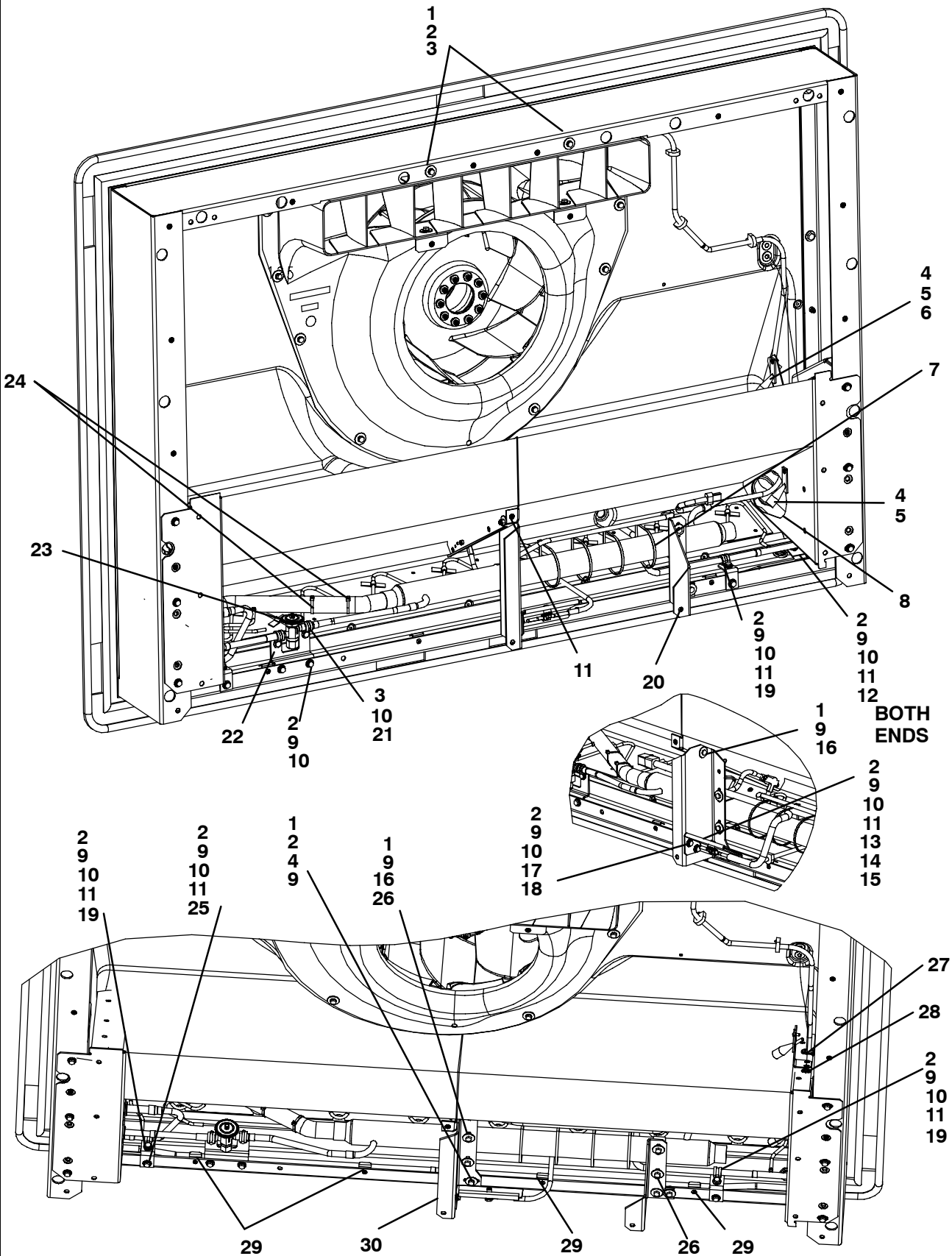

5.4 EVAPORATOR - HARDWARE

Item	Part Number	Description	Qty
1	34-00662-20	WASHER, FLAT, 9/32 I.D. SPECIAL - SST	15
2	34-00663-11	WASHER, LOCK, 1/4 - SST	17
3	34-00655-08	SCREW, CAP HEX HEAD, 1/4-20 X 1.00 LG. - SST	4
4	34-00928-13	RIVET, BLIND, .187 DIAMETER, .126-.250 GRIP RANGE	4
5	58-00793-00	FITTING, AIR SENSING	2
6	68-10745-00	BRACKET, UPPER AIR FITTING	1
7	58-00079-00	STA-STRAP, 0-4.00" DIAMETER CABLE	4
8	58-00523-01	EXTRUSION, U-SHAPED	A / R
9	34-00655-06	SCREW, CAP HEX HEAD, 1/4-20 X .75 LG. - SST	23
10	34-00662-11	WASHER, FLAT, 1/4 - SST	21
11	34-06051-36	RIVNUT, 1/4-20	A / R
12	68-07729-00	CLAMP, DRAIN PAN HEATER LINE	2
13	34-00373-51	CLAMP, TUBE, .25 DIAMETER CUSHION	1
14	42-01170-07	GASKET, RAS SHIELD, 4" X 5" X .13" THK	1
15	58-00836-04	SPACER, NYLON, (.625" OD X .281" ID X .25" L)	1
16	34-00667-111	NUT, SELF LOCK, 1/4-20	5
17	34-06051-37	RIVNUT, 1/4-20	2
18	86-03013-00	SHIELD ASSEMBLY, AIR SENSOR	1
19	44-01134-08	CLAMP, TUBE, .50 ID CUSHIONED	2
20	68-12676-00	BRACKET, SUPPORT, HEAT EXCHANGER, CS	1
21	34-00373-07	CLAMP, TUBE, .62 I.D.	2
22	68-07670-00	BRACKET, TXV	1
23	42-00032-00	INSULATION, PRESSTITE (30 FT ROLL)	A / R
24	58-00079-02	STA-STRAP, 0-1.75" DIAMETER CABLE	2
25	68-07730-00	BRACKET, DRAIN PAN HEATER SUPPORT	2
26	34-00558-09	CLAMP, HEAT EXCHANGER, 2.12 DIAMETER, SST.	2
27	58-00065-66	GROMMET, (.56 I.D. X .81 O.D.)	1
28	58-00065-14	GROMMET, (.38 I.D. X .62 O.D.)	1
29	68-14694-00	CLIP, SPRING, DRAIN PAN HEATER LINE	4
30	68-12632-00	BRACKET, CENTER EVAP SUPPORT	1

5.5 EVAPORATOR - TUBING AND WIRING

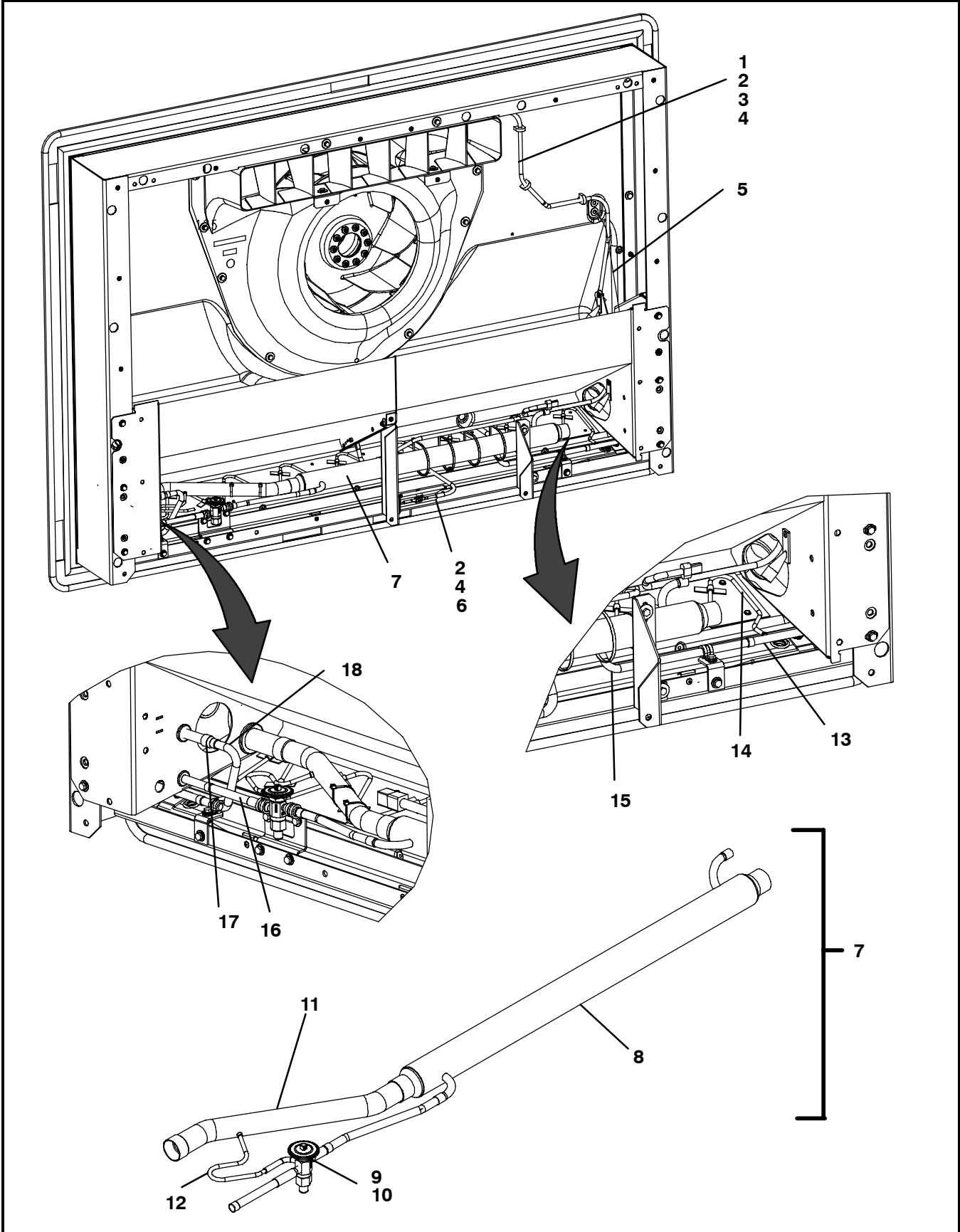

5.5 EVAPORATOR - TUBING AND WIRING

Item	Part Number	Description	Qty
1	22-01951-00	HARNESS, DTT - INCLUDES:	2
2	12-00523-01	THERMISTOR, SENSOR, SAS / RAS	2
3	12-00495-03	THERMISTOR, DTT	1
4	22-50098-58	CONNECTOR, 4-WIRE (MATES WITH 22-50098-57)	1
5	58-01149-00	TUBING, RED, AIR SWITCH (SOLD PER FOOT)	A / R
6	22-01951-01	HARNESS, RETURN AIR RAS - INCLUDES:	1
2	12-00523-01	THERMISTOR, SENSOR, SAS / RAS	1
4	22-50098-58	CONNECTOR, 4-WIRE (MATES WITH 22-50098-57)	1
7	81-01653-01	HEAT EXCH. ASSEMBLY, X2 2500 A/R - INCLUDES:	1
	81-01653-02	HEAT EXCH. ASSEMBLY, X2 2100 A/R- INCLUDES:	1
8	08-00197-01	HEAT EXCHANGER, LSHX	1
9	14-00232-28	VALVE, EXPANSION, TXV, X2 2500 A/R ONLY	1
	14-00232-25	VALVE, EXPANSION, TXV, X2 2100 A/R ONLY	1
10	14-00176-02	STRAINER	1
11	56-07300-00	TUBE, 1-3/8" OD SUCTION LINE	1
12	56-07401-00	TUBE, 1/4" OD, EQUALIZER LINE	1
13	56-03770-00	TUBE, 1/2" OD, DRAIN PAN HEATER, CS	1
14	86-04249-01	PLATE ASSEMBLY, DEFROST, SERPENTINE	1
15	56-08081-00	TUBE, 1/2" OD HOT GAS LINE	1
16	56-03768-00	TUBE, 1/2" OD, DRAIN PAN HEATER, RS	1
17	40-00130-07	COUPLING, REDUCING, 5/8 X 1/2" ODS	1
18	56-03769-00	TUBE, 1/2" OD, DRAIN PAN HEATER TO DISTRBTR.	1

6 FRESH AIR EXCHANGE - AFAX

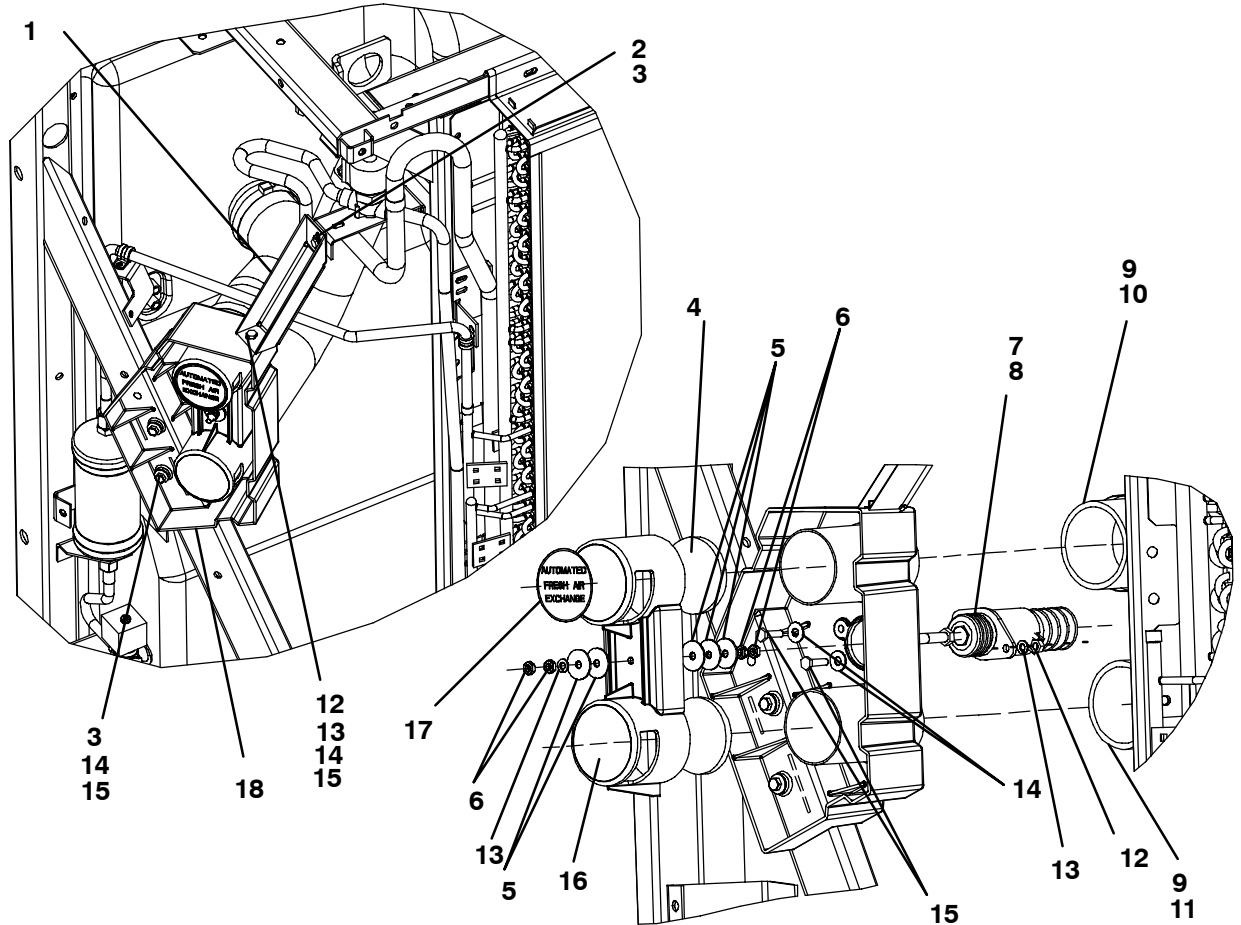

Item	Part Number	Description	Qty
1	86-04616-00	BRACKET ASSEMBLY, AFAX SUPPORT	1
2	34-00918-06	SCREW, HX WASHHD, 1/4-20 X .75" L	1
3	34-06051-06	RIVNUT, 1/4-20	3
4	42-00606-01	GASKET, FRESH AIR	2
5	34-00699-03	WASHER, PLAIN, 1/4" ID	5
6	34-00636-11	NUT, JAM, 1/4-28	4
7	10-00591-00	SOLENOID, PUSH, 12 VDC, AFAX - INCLUDES:	1
8	22-50098-56	CONNECTOR, 2-WIRE (MATES WITH 22-50078-22)	1
9	44-00045-20	CLAMP, HOSE, 3.06-4.00"	4
10	58-04652-00	HOSE, UPPER, FRESH AIR INLET	1
11	58-04653-00	HOSE, LOWER, FRESH AIR OUTLET	1
12	34-00363-11	NUT, HEX, 1/4-20	3
13	34-00663-11	WASHER, LOCK, 1/4"	4
14	34-00366-11	WASHER, PLAIN, 1/4"	5
15	34-00300-08	SCREW, CAP HXHD, 1/4-20 X 1.00	5
16	58-04700-01	COVER, AIR EXCHANGE	1
17	62-11106-01	DECAL, AFAX	1
18	58-04698-01	HOUSING, AIR EXCHANGE	1

7 POWER TRAIN

7.1 UPPER POWER TRAIN - FRONT VIEW

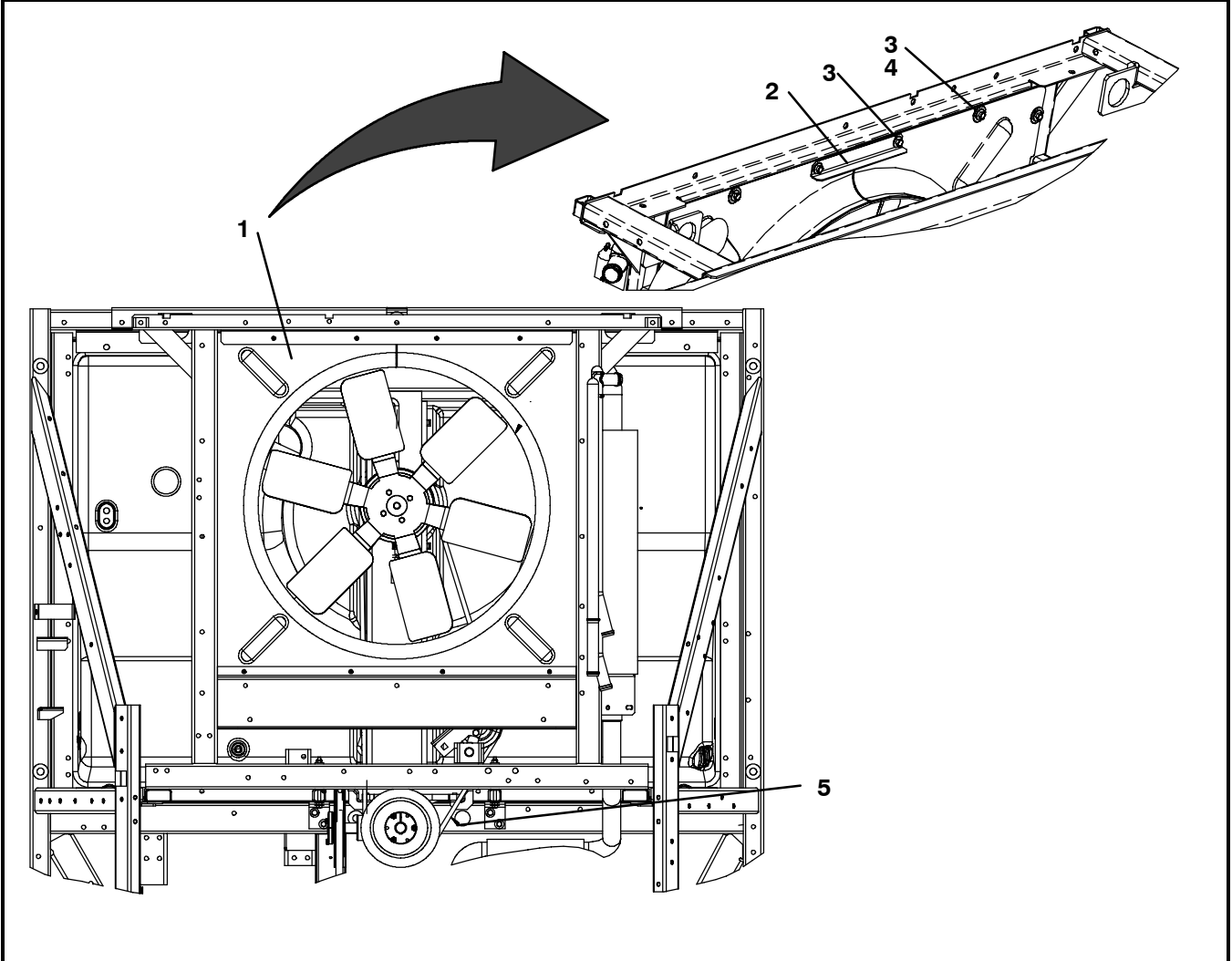

Item	Part Number	Description	Qty
1	58-04472-00SV	SHROUD, CONDENSER - INCLUDES:	1
2	68-15092-00	ANGLE, COND. SHROUD	1
3	34-01294-08	SCREW, HEX WASHERHEAD, 1/4-20 X 1.00 LG. - STEEL	16
4	34-00699-03	WASHER, FLAT, 1/4 I.D. X 1.12 O.D. - STEEL	14
5	50-00178-26	V-BELT, COND FAN, BX SECTION, X2 2500 A/R ONLY	1
	50-00178-24	V-BELT, COND FAN, BX SECTION, X2 2100 A/R ONLY	1
6	50-01152-02	IDLER ASSEMBLY, COND FAN BELT - SEE SECTION 7.1.1	1

7.1.1 UPPER POWER TRAIN - IDLER ASSEMBLY

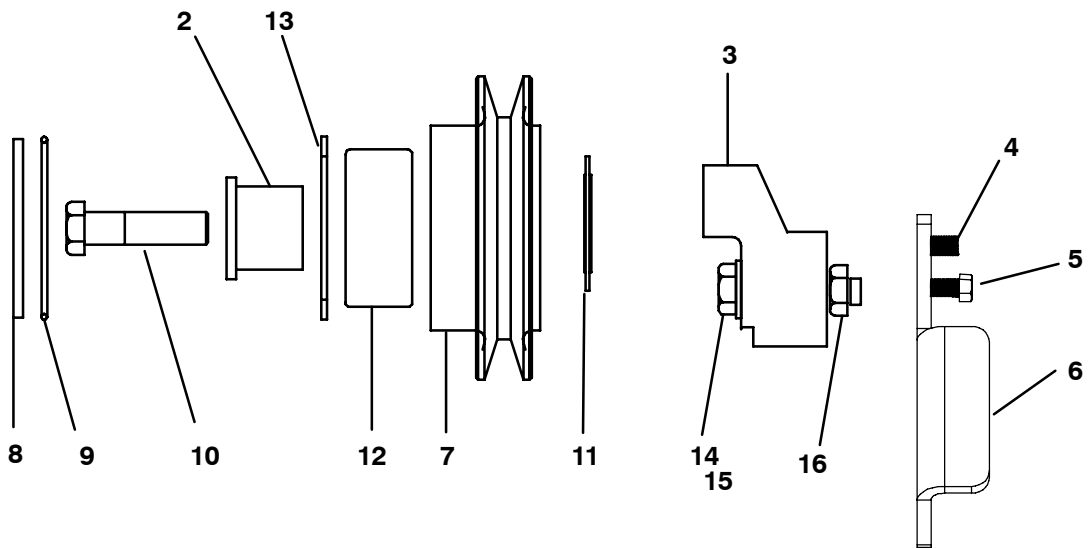

7.1.1 UPPER POWER TRAIN - IDLER ASSEMBLY

Item	Part Number	Description	Qty
1	50-01152-02	IDLER ASSEMBLY, COND FAN BELT - INCLUDES:	1
2	50-01152-26	BUSHING, BEARING	1
3	48-00267-00	BRACKET, IDLER	1
4	34-06315-00	STUD, HXHD, 7/16-20 X 1" L	1
5	34-00302-06	BOLT, HXHD, 5/16-18 X 3/4" L	1
6	68-15333-00	PLATE, IDLER ADJUST	1
7	50-01152-22SV	PULLEY ASSEMBLY, 4.50 IN. DIAMETER - INCLUDES:	1
8	NSS	COVER, DUST	1
9	NSS	O-RING	1
10	50-01152-52	BOLT, SHOULDER, 7/16-20 X 1-1/2" L	1
11	NSS	SHIELD, BEARING	1
12	50-01152-25SV	BEARING ASSEMBLY, IDLER PULLEY - INCLUDES:	1
11	NSS	SHIELD, BEARING	1
13	NSS	RING, SNAP	1
9	NSS	O-RING	1
8	NSS	COVER, DUST	1
14	34-00368-15	WASHER, LOCK, 1/2"	1
15	34-00675-14	SCREW, CAP HXHD, 1/2-20 X 1.75 GRADE 8	1
16	34-06316-00	NUT, JAM, 7/16 - 14	1

7.2 POWER TRAIN - FAN SHAFT AND CLUTCH

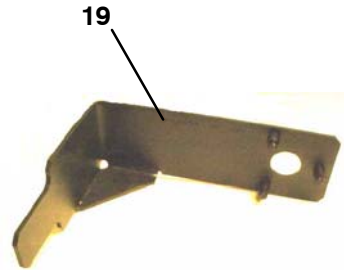
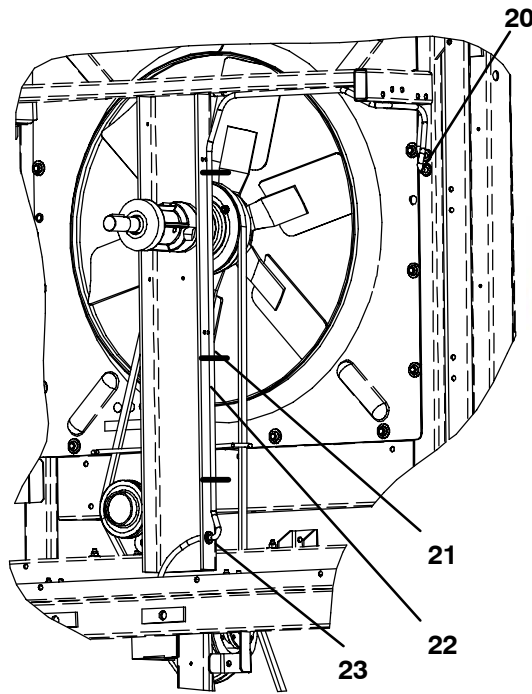
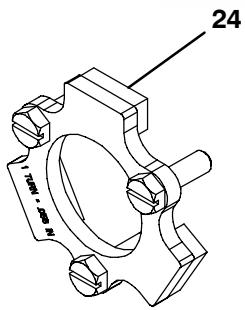
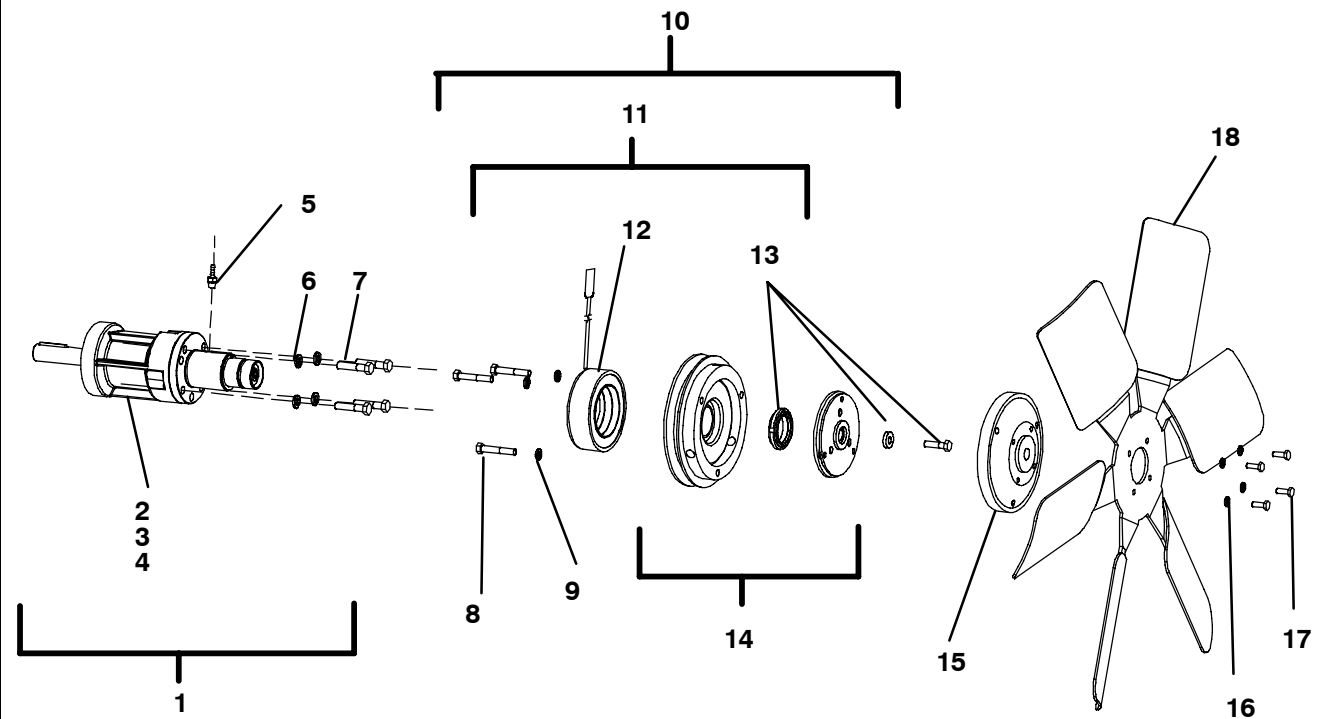

CURBSIDE VIEW

7.2 POWER TRAIN - FAN SHAFT AND CLUTCH

Item	Part Number	Description	Qty
1	50-00232-09SV	SHAFT ASSEMBLY, FAN - INCLUDES:	1
2	04-00122-30	BUSHING, SPLIT TAPER 1.188 BORE	A / R
3	34-00775-10	SCREW, 1/4"-20 X 1-1/4" L	2
4	34-00368-11	LOCKWASHER, 1/4"	2
5	40-00420-00	FITTING, HOSE, BARB 3/16 I.D. X 1/8 MPT	1
6	34-00368-13	WASHER, LOCK, 3/8 SPRING - STEEL	4
7	34-00304-14	SCREW, CAP HEX HEAD, 3/8-16 X 1.75 LG.	4
8	34-00615-16	SCREW, CAP HEX HEAD, 5/16-18 X 2.00 LG.	3
9	34-00368-12	WASHER, LOCK, 5/16 SPRING	3
10	50-00236-05	FAN CLUTCH ASSEMBLY - INCLUDES:	1
11	50-00236-33	FIELD COIL ASSEMBLY - INCLUDES:	1
12	22-50078-01SV	CONNECTOR, 2-WIRE (MATES WITH 22-50078-02SV)	1
13	50-00236-32	MOUNTING ACCESSORIES	1
14	50-00236-31	ARMATURE AND ROTOR ASSEMBLY - INCLUDES:	1
13	50-00236-32	MOUNTING ACCESSORIES	1
15	48-00347-01	ADAPTER, CONDENSER FAN	1
16	34-00368-11	WASHER, LOCK, 1/4 SPRING	4
17	34-00775-06	SCREW, CAP HEX HEAD, 1/4-20 X .75 LG.	4
18	38-00528-00	FAN, CONDENSER	1
19	07-00396-01	SPANNER WRENCH, CLUTCH	1
20	58-00065-62	GROMMET, (.44 I.D. X .12)	1
21	58-00079-00	STA-STRAP, 0-4.00 DIAMETER CABLE	6
22	58-00659-00	HOSE, FUEL, 3/16" ID X 25 FT LONG	A / R
23	58-00065-80	GROMMET, .50 ID	1
24	07-00432-00	GAUGE, AIR GAP	1
25	07-00303-02	CLUTCH NUT TOOL	1

7.3 POWER TRAIN - DRIVE

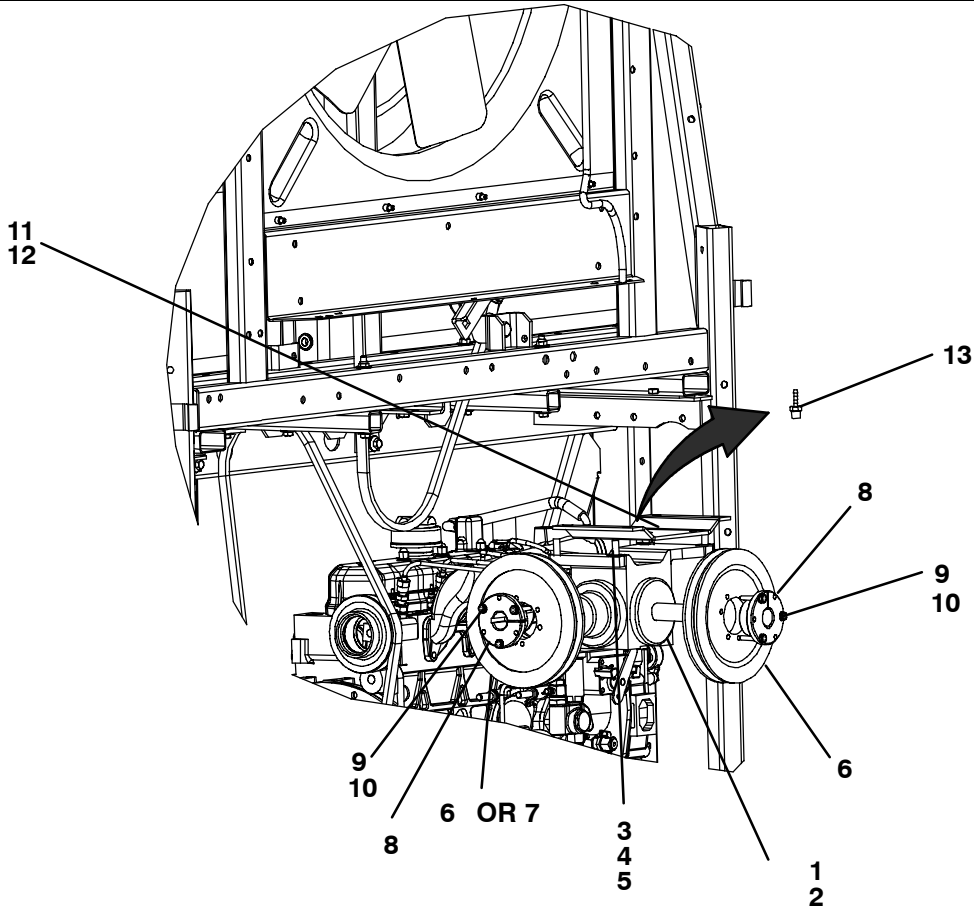

Item	Part Number	Description	Qty
1	50-00240-00	GEARBOX, RIGHT ANGLE DRIVE - INCLUDES:	1
2	50-00214-47	KEY, 1/4 SQUARE X 1.5"	2
3	34-00366-13	WASHER, FLAT, 3/8 - STEEL	4
4	34-00368-13	WASHER, LOCK, 3/8 SPRING - STEEL	4
5	34-00304-08	SCREW, CAP HEX HEAD, 3/8-16 X 1.00 LG. - STEEL	4
6	50-00224-04	SHEAVE, SINGLE GROOVE, 5.75 DIAMETER, X2 2500 A/R ONLY	1
	50-00224-00	SHEAVE, SINGLE GROOVE, 7.75 OD., X2 2100 A/R ONLY	1 / 2
7	50-00224-00	SHEAVE, SINGLE GROOVE, 7.75 OD	1
8	04-00058-00	BUSHING, SPLIT, 1.00 BORE	2
9	34-00775-12	SCREW, CAP HXHD, 1/4-20 X 1-1/2	6
10	34-00368-11	WASHER, LOCK, 1/4"	6
11	86-04437-00	PLATE ASSEMBLY, RIGHT ANGLE DRIVE MTG.	1
12	34-00919-08	SCREW, HEX WASHERHEAD, 5/16-18 X 1.00 LG.	4
13	40-00420-02	FITTING, HOSE	1

8 UNIDRIVE ASSEMBLY

8.1 UNIDRIVE - MOUNTING AND ENGINE

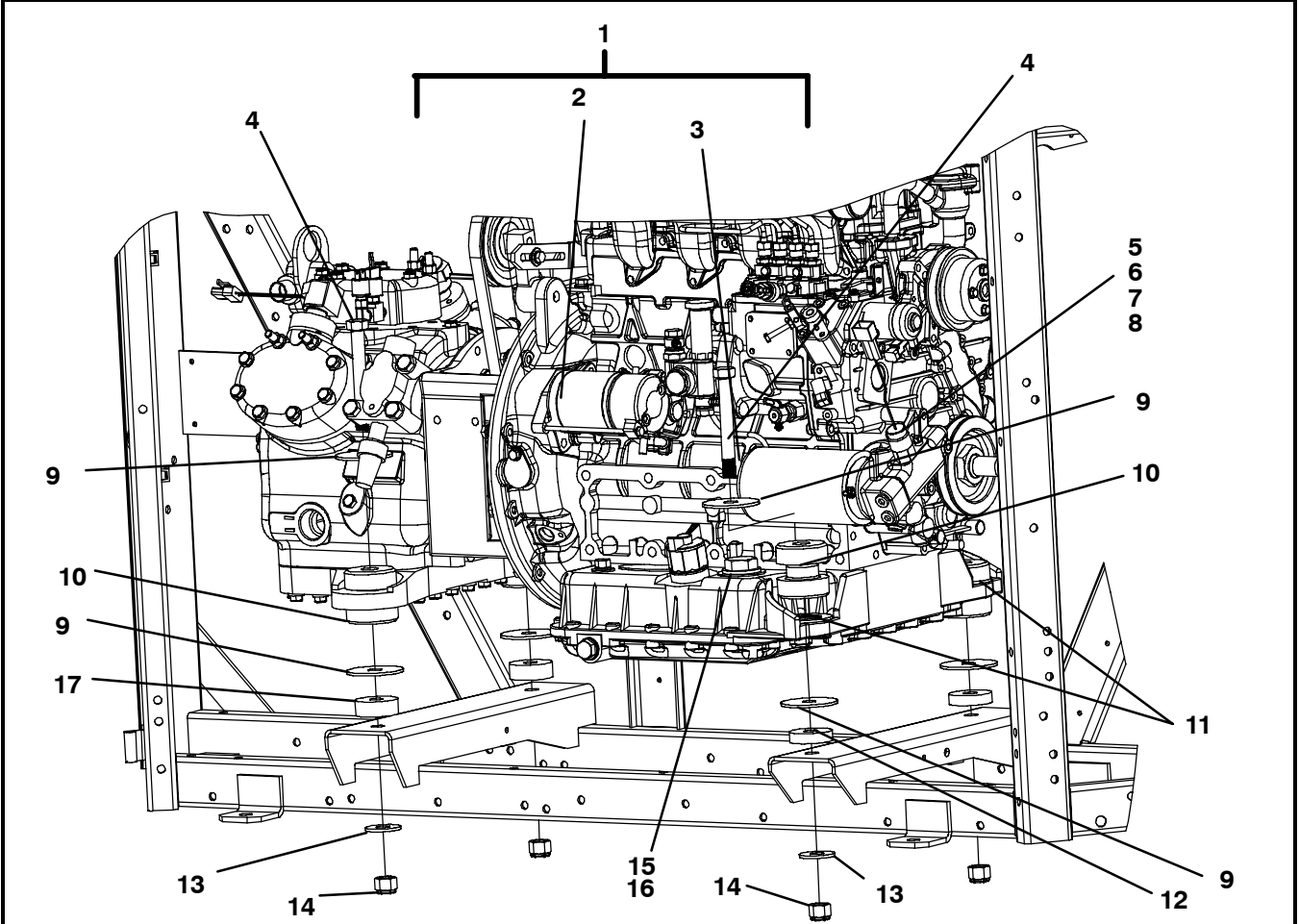

Item	Part Number	Description	Qty
1	26-00120-00	ENGINE, KUBOTA V2203-DI (ESC), X2 2500 A/R - INCLUDES:	1
	26-00120-01	ENGINE, KUBOTA V2203-DI (ESC), X2 2100 A/R - INCLUDES:	1
2	25-39316-00	STARTER	1
3	30-00463-00P12	OIL FILTER, ESI (SOLD IN A CASE OF 12)	1
4	34-00676-40	SCREW, CAP HXHD, 5/8-18 X 5.0	4
5	12-00592-00	SWITCH, OIL PRESSURE (OPS) - INCLUDES:	1
6	22-50078-01SV	CONNECTOR, 2-WIRE (MATES WITH 22-50078-02SV)	1
7	58-00079-02	STA-STRAP, 0-1.75" DIAMETER CABLE	2
8	58-00858-00	TUBE, SLIT, CORRUGATED, 1/4 ID X 25FT LONG	A/R
9	34-00890-07	WASHER, FLAT, 0.657 I.D. X 2.81 O.D.	8
10	73-00160-02	SHOCKMOUNT, ENGINE / COMPRESSOR	4
11	34-00890-10	WASHER, FLAT, 1.58" ID	2
12	48-00273-02	SPACER, ENGINE, 2-1/8" X 1/2" THICK	2
13	34-00366-17	WASHER, PLAIN, 5/8"	4
14	34-00927-00	NUT, SELF LOCK, 5/8-18	4
15	12-00589-02	SENSOR, OIL LEVEL - INCLUDES:	1
16	22-50078-02SV	CONNECTOR, 2-WIRE (MATES WITH 22-50078-01SV)	1
17	48-00273-00	SPACER, COMPRESSOR, 2-1/8 OD X 3/4" THICK	2

8.2 UNIDRIVE - COMPRESSOR ASSEMBLY

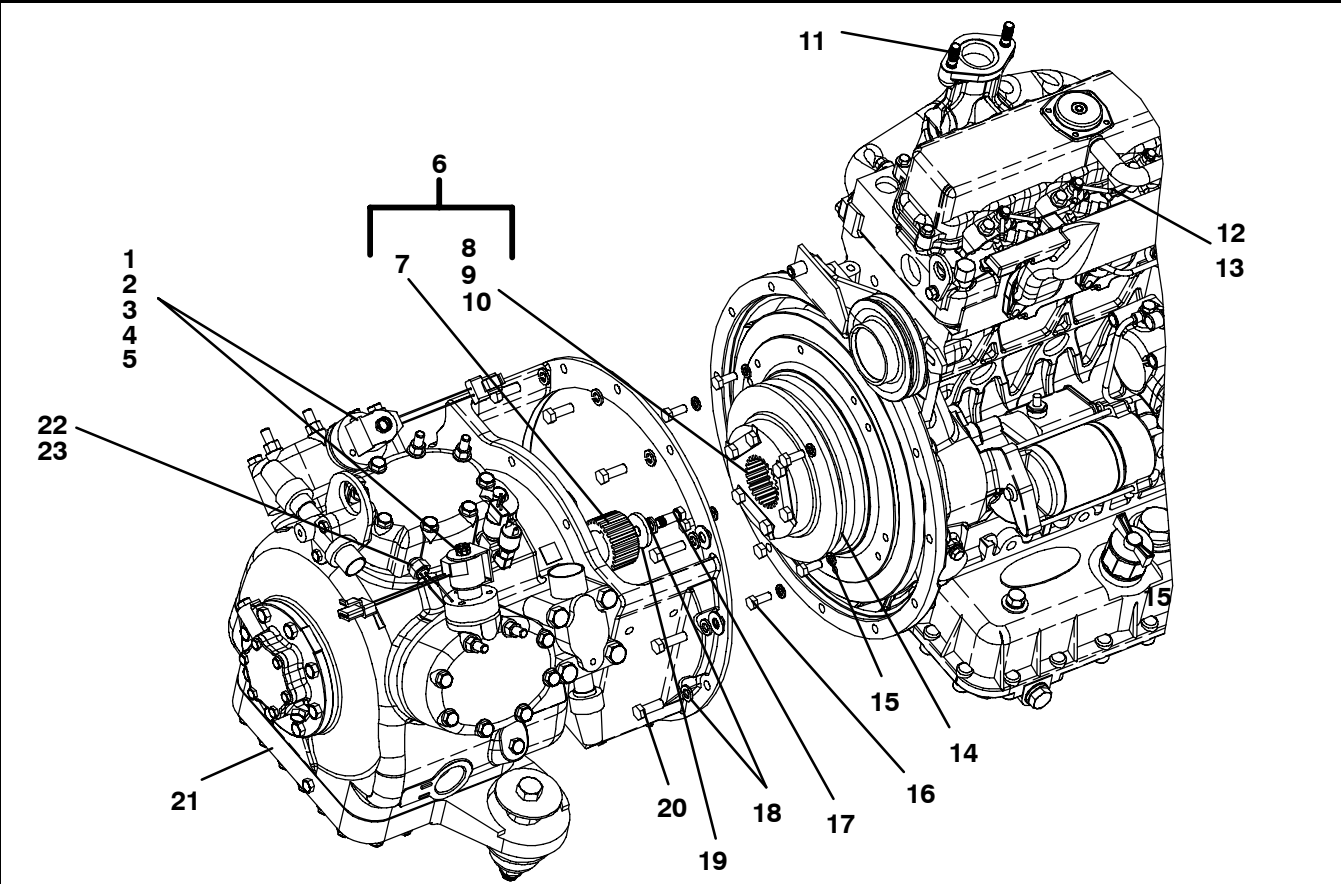

Item	Part Number	Description	Qty
1	22-02804-00	COIL, COMPRESSOR UNLOADER - INCLUDES:	2
2	22-50078-02SV	CONNECTOR, 2-WIRE (MATES WITH 22-50078-01SV)	2
3	34-06026-00	ROLL PIN, .062 DIAMETER X .18	2
4	58-00079-02	STA-STRAP, 0-1.75" DIAMETER CABLE	A / R
5	58-00858-00	TUBE, SLIT, CORRUGATED, 1/4 ID X 25 FT LONG	A / R
6	48-50005-00	DRIVE GEAR KIT, COMPRESSOR - INCLUDES:	1
7	NSS	COMPRESSOR GEAR, STEEL	1
8	50-00230-00	NYLON COUPLING GEAR	1
9	68-12650-00	LOCKING BARS	3
10	34-00304-14	BOLT, 3/8-16 X 1 3/4, GRADE 5	6
11	34-00964-00	STUD, EXHAUST MANIFOLD, M10 X 3/8-24 X 1.50" L	2
12	12-01145-03	THERMISTOR, ENGINE TEMP - INCLUDES:	1
13	22-50078-02SV	CONNECTOR, 2-WIRE (MATES W/22-50078-01SV)	1
14	48-00327-01	SHEAVE, COMPRESSOR DRIVE	1
15	34-00945-08	WASHER, LOCK, M8	6
16	34-01241-20	SCREW, CAP HEX HEAD, M8 X 20 MM - STEEL	6
17	34-00559-08	SCREW, CAP HXHD, 3/8-24 X 1.00	1
18	34-00368-13	WASHER, LOCK, 3/8"	12
19	34-00616-00	WASHER, PLAIN, .406" ID	1
20	34-00304-08	SCREW, CAP HXHD, 3/8-16 X 1.00	12
21	18-00091-105	COMPRESSOR, 41 CFM, 05G TWINPORT	1
22	12-00284-00	THERMISTOR, COMPRESSOR TEMPERATURE (CDT) - INCLUDES:	1
23	22-01585-00SV	CONNECTOR, FEMALE	6

8.3 UNIDRIVE - HIGH PRESSURE SWITCH, IDLER AND V-BELT MOUNTING

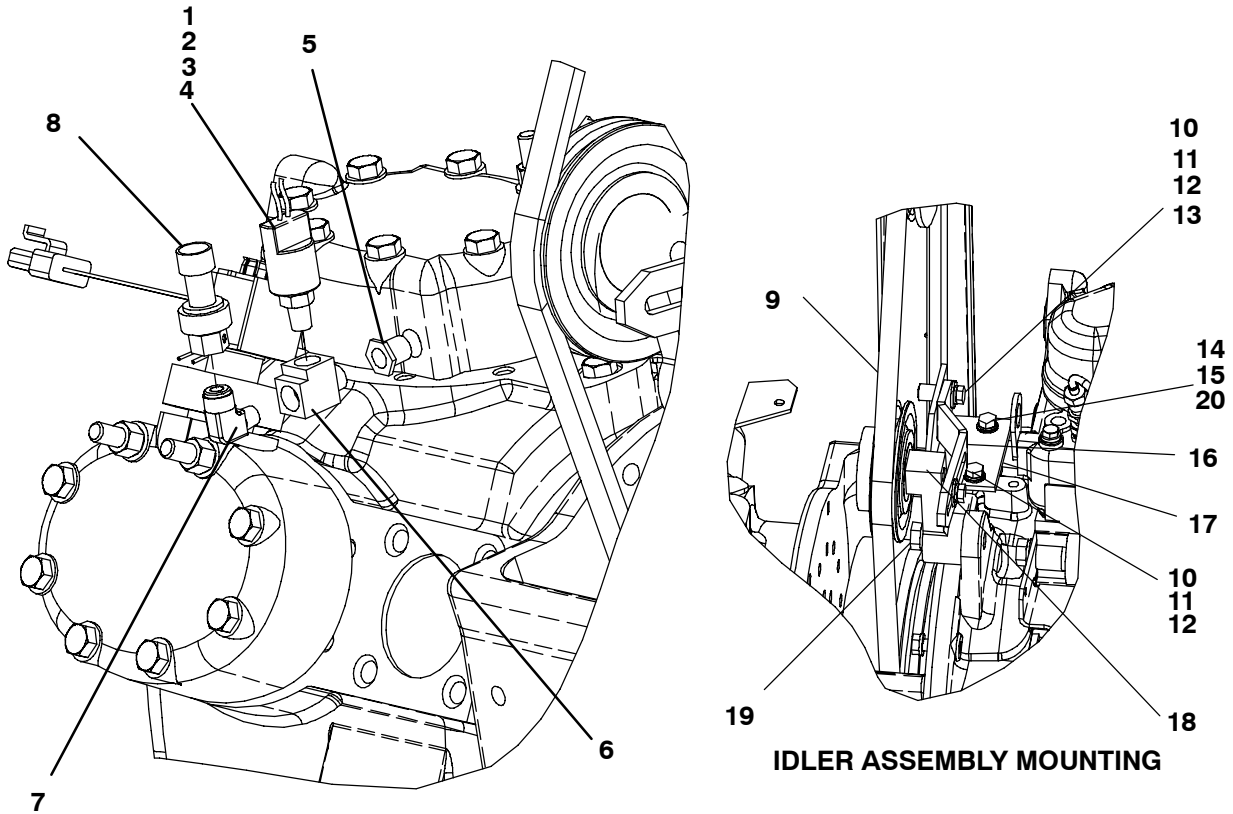

Item	Part Number	Description	Qty
1	12-00309-04	SWITCH, PRESSURE, 465 / 350 PSIG (HP1) - INCLUDES:	1
2	22-02392-00SV	CONNECTOR, 2-WIRE (MATES WITH 22-01585-00SV)	1
3	58-00079-02	STA-STRAP, 0-1.75" DIAMETER CABLE	A / R
4	58-00858-00	TUBE, SLIT, CORRUGATED, 1/4 ID X 25FT LONG	A / R
5	40-00121-01	BUSHING, 1/4 NPT X 1/8 NPT	1
6	40-00243-00	TEE, STREET, 1/8 MPT X 1/8 X 1/8 FPT	1
7	40-00593-00	ELBOW, 90° STREET, 1/4 FLARE X 1/8 NPT	1
8	12-00352-04	TRANSDUCER, DISCHARGE PRESSURE, 0/500 PSIG HP2 (MATES WITH 22-02448-00SV)	1
9	50-00178-19	V-BELT, B SECTION, LOWER DRIVE	1
10	34-00302-10	SCREW, CAP HEX HEAD, 5/16-18 X 1.25 LG.	2
11	34-00366-12	WASHER, PLAIN, 5/16"	2
12	34-00368-12	WASHER, LOCK, 5/16"	2
13	34-06051-11	RIVNUT, 5/16-18	1
14	34-00945-08	WASHER, LOCK, M8 - STEEL	2
15	34-00944-08	WASHER, FLAT, M8	2
16	68-07438-03	STRAP, IDLER MOUNTING	1
17	68-11608-00	ANGLE, IDLER STRAP MOUNTING	1
18	50-01152-00	IDLER ASSEMBLY - REFER TO SECTION 8.3.1	1
19	34-00309-14	SCREW, CAP HXHD, 1/2-20 X 1.75	1
20	34-00876-20	SCREW, CAP HXHD, M8 X 20 MM (0.79)	2

8.3.1 UNIDRIVE - IDLER ASSEMBLY

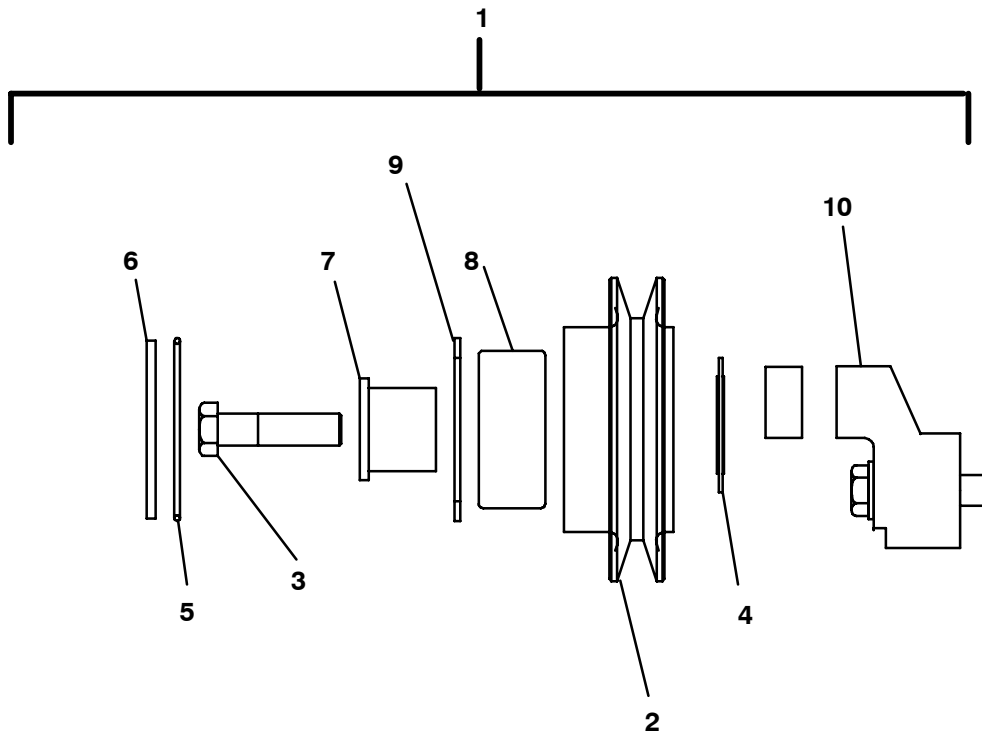

8.3.1 UNIDRIVE - IDLER ASSEMBLY

Item	Part Number	Description	Qty
1	50-01152-00	IDLER ASSEMBLY, LOWER DRIVE - INCLUDES:	1
2	50-01152-22SV	PULLEY ASSEMBLY, 4.50 IN. DIAMETER - INCLUDES:	1
3	50-01152-28	BOLT, SHOULDER, 7/16-20 X 1-3/4" L	1
4	NSS	SHIELD, BEARING	1
5	NSS	O-RING	1
6	NSS	DUST COVER	1
7	50-01152-26	BUSHING, BEARING	1
8	50-01152-25SV	BEARING ASSEMBLY, IDLER PULLEY - INCLUDES:	1
4	NSS	SHIELD, BEARING	1
9	NSS	RING, SNAP	1
5	NSS	O-RING	1
6	NSS	COVER, DUST	1
10	48-00267-00	BRACKET, IDLER	1

8.4 ALTERNATOR ASSEMBLY

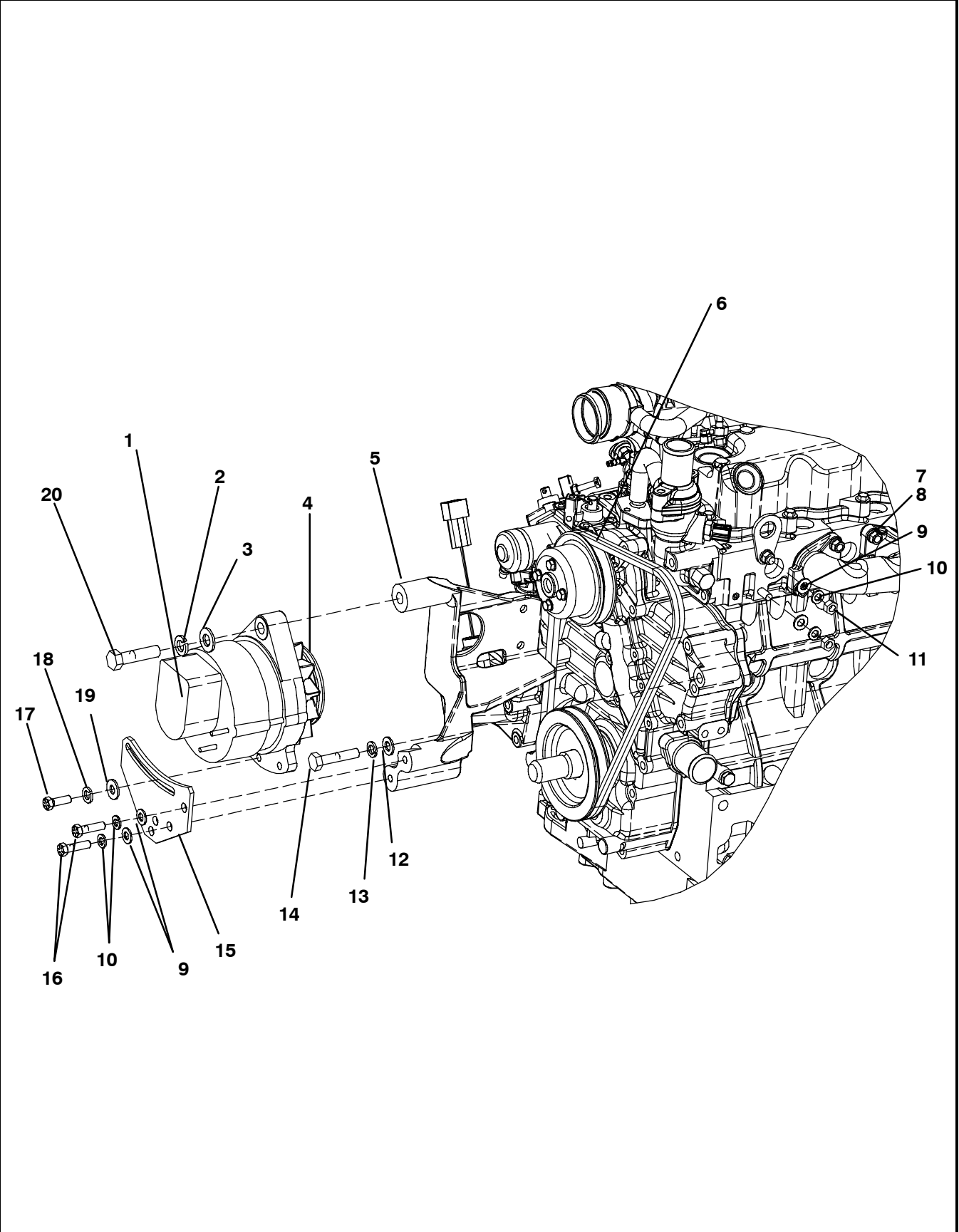

8.4 ALTERNATOR ASSEMBLY

Item	Part Number	Description	Qty
1	30-00409-65	ALTERNATOR, 65-AMP, LESS PULLEY - REFER TO SECTION 8.4.1	1
	30-00409-11	ALTERNATOR, 105-AMP, LESS PULLEY - REFER TO SECTION 8.4.1	1
2	34-00368-15	WASHER, LOCK, 1/2	1
3	34-00588-15	WASHER, FLAT, 1/2	1
4	50-01123-13	PULLEY, ALTERNATOR, 2.70" DIAMETER	1
5	48-00373-02	BRACKET, ALTERNATOR	1
6	50-00162-25	V-BELT, NOTCHED, WATERPUMP / ALTERNATOR	1
7	12-01145-03	THERMISTOR, ENGINE TEMPERATURE (WTS) - INCLUDES:	1
8	22-50078-02SV	CONNECTOR, FEMALE	1
9	34-00588-12	WASHER, FLAT, 5/16	4
10	34-00368-12	WASHER, LOCK, 5/16	4
11	34-00946-08	NUT, HEX, M8 X 1.25	2
12	34-00944-10	WASHER, FLAT, M10	1
13	34-00945-10	WASHER, LOCK, M10	1
14	34-00873-50	SCREW, CAP HXHD, M10 X 50 MM (1.97) LG	1
15	68-14422-00	PLATE, ALTERNATOR ADJUSTING	1
16	34-00615-10	SCREW, CAP HEX HEAD, 5/16-18 X 1.25 LG.	2
17	34-00615-08	SCREW, CAP HEX HEAD, 5/16-18 X 1.00 LG.	1
18	34-00368-13	WASHER, LOCK, 3/8"	1
19	34-01279-12	WASHER, FLAT, 5/16	1
20	34-00678-16	SCREW, CAP HEX HEAD, 1/2-13 X 2.00 LG	1

8.4.1 ALTERNATOR

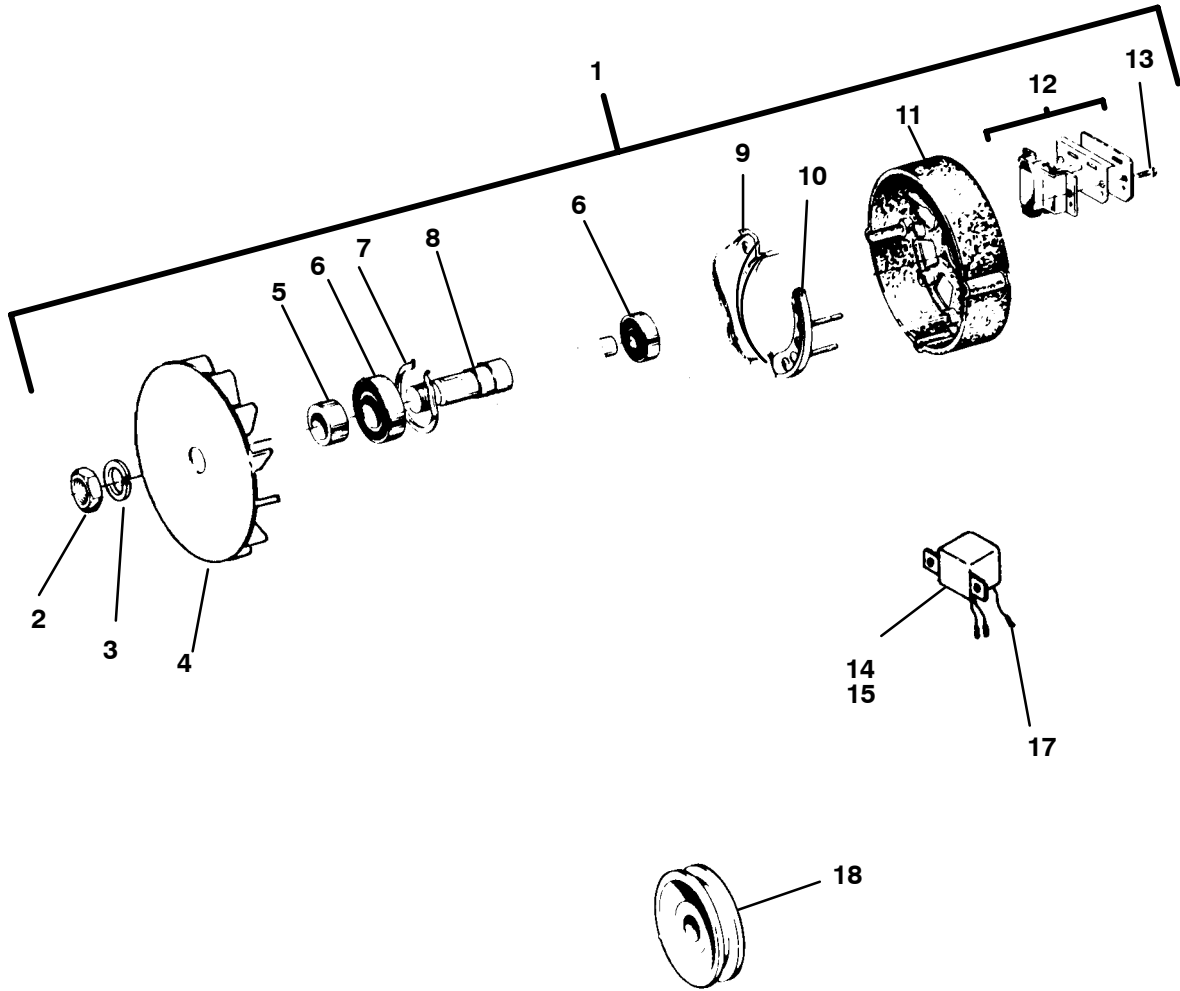

8.4.1 ALTERNATOR

Item	Part Number	Description	Qty
1	30-00409-65	ALTERNATOR, 65-AMP, LESS PULLEY - INCLUDES:	1
	30-00409-11	ALTERNATOR, 105-AMP, LESS PULLEY - INCLUDES:	1
2	30-00171-13	NUT, PULLEY	1
3	30-00171-29	WASHER, SPRING LOCK (5/8)	1
4	30-00409-57	FAN, COUNTER-CLOCKWISE ROTATION	1
5	30-00409-53	SPACER, FAN	1
6	30-00409-51	BEARING, FRONT AND REAR	2
7	30-00409-52	RETAINER CLIP	1
8	30-00171-31	KEY, WOODRUFF	1
9	30-00409-56	RECTIFIER, NEGATIVE	1
10	30-00409-55	RECTIFIER, POSITIVE	1
11	30-00409-54	END FRAME	2
12	30-00409-30	BRUSH ASSEMBLY	1
13	30-00409-32	SCREW, THROUGH BOLT	1
14	30-00409-44	REGULATOR	1
15	66U1-2233-33	GASKET, REGULATOR	1
16	30-00409-35	SCREW, BRUSH HOLDER	1
17	22-50078-07SV	CONNECTOR, 1-WIRE (MATES WITH 22-50078-21SV)	1
18	50-01123-13	PULLEY, ALTERNATOR, 2.70" DIA.	1

9 FUEL FILTER

9.1 STANDARD FUEL FILTER

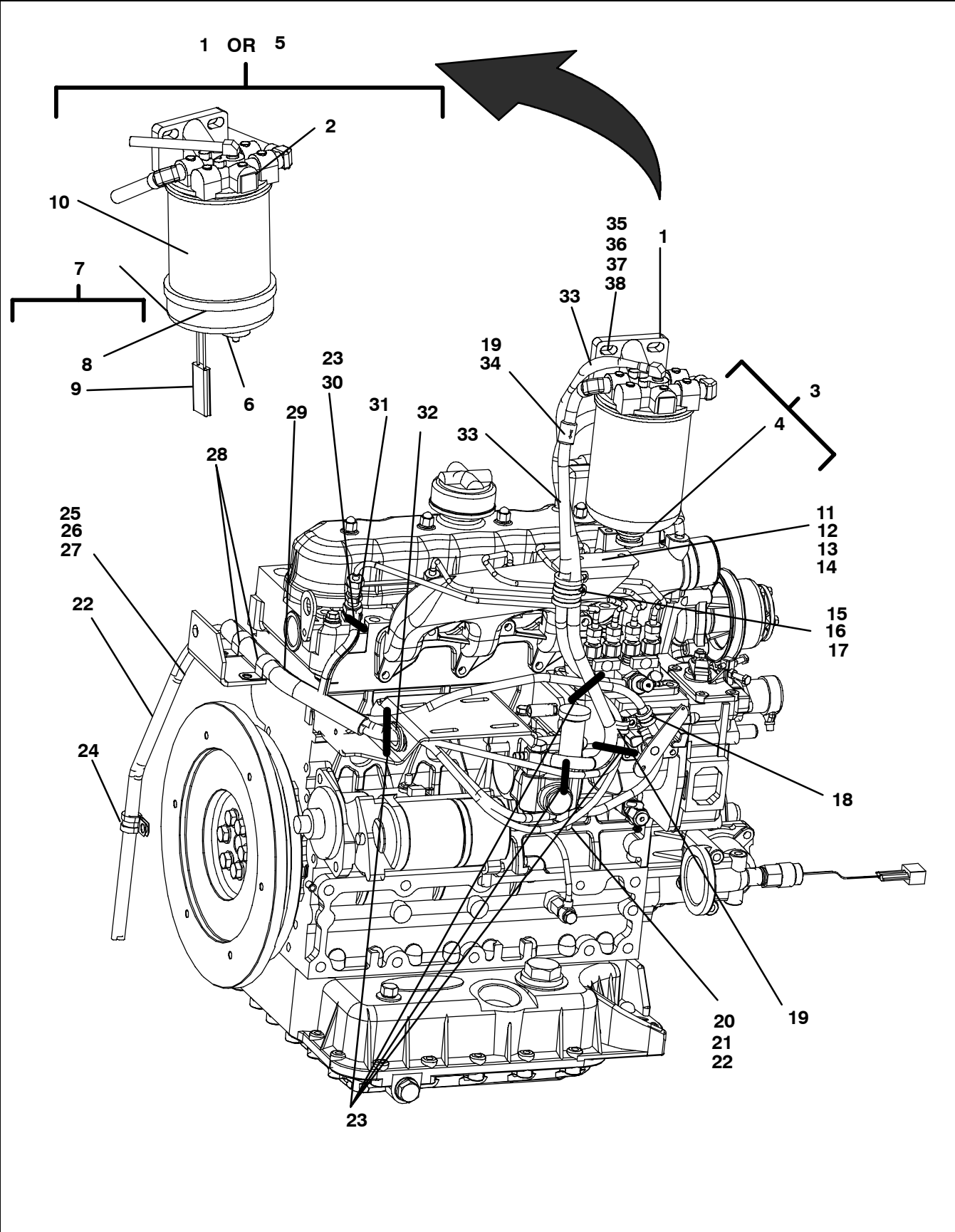

9.1 STANDARD FUEL FILTER

Item	Part Number	Description	Qty
1	30-01104-04	FILTER ASSEMBLY, FUEL, WITHOUT HEATER - INCLUDES:	1
2	30-01104-50	FILTER HEAD, FUEL, WITH FITTINGS	1
3	30-01090-04	FILTER , FUEL, WITH WATER SEP. AND DRAIN - INCLUDES:	1
4	30-01090-11	DRAIN, FUEL FILTER (WITH O-RING)	1
5	30-01104-05	FILTER ASSEMBLY, FUEL, WITH HEATER - INCLUDES:	1
2	30-01104-50	FILTER HEAD, FUEL, WITH FITTINGS	1
6	30-01098-27	DRAIN PLUG ASSEMBLY	1
7	30-01104-51	HEATER BOWL ASSEMBLY - INCLUDES:	1
8	30-01098-28	GASKET, HEATER BOWL	1
9	22-50078-01SV	CONNECTOR, 2-WIRE (MATES WITH 22-50078-02SV)	1
10	30-01079-01	FILTER ELEMENT, FUEL, BOWL TYPE	1
11	34-00876-20	SCREW, CAP HXHD, M8 X 20 MM (0.79)	2
12	34-00944-08	WASHER, FLAT, M8	2
13	34-00945-08	WASHER, LOCK, M8	2
14	68-14894-00	ANGLE, FUEL LINE SUPPORT	1
15	34-00373-15	CLAMP, TUBE, 1.12 DIAMETER CUSHION	1
16	34-01294-08	SCREW, CAPT. WASH, 1/4-20 X 1.00	1
17	34-06051-07	RIVNUT, 1/4-20	1
18	34-00373-05	CLAMP, TUBE, .50 DIAMETER CUSHION	1
19	44-01168-00	CLAMP, HOSE, FUEL LINE	4
20	40-01153-00	BANJO, FUEL SYSTEM	1
21	42-01133-00	SEAL, BONDED, M14 (STEEL / RUBBER)	2
22	58-00508-99	TUBE, BLACK, .375 OD (SOLD IN 50 FT ROLL)	A / R
23	58-00079-02	STA-STRAP, 0-4.00 DIAMETER CABLE	6 / 9
24	44-00102-02	CLAMP, CUSHIONED, .56 DIAMETER	1
25	79-02305-00	TUBE ASSEMBLY, FUEL - INCLUDES:	1
26	40-01156-00	TEE, FUEL, 3/16" HOSE X 1/4" TUBE X 3/16" HOSE	1
27	44-00293-07	CLAMP, STEPLESS EAR, 15/32" DIAMETER	1
28	44-01137-19	CLAMP, CONDUIT, 16 MM DIAMETER	2
29	58-00849-00	TUBE, SLIT, 5/8" ID X 7.5 FT LOG	A / R
30	58-00848-00	TUBE, SLIT, 1/2" ID (SOLD IN 25 FT ROLL)	A / R
31	44-00293-06	CLAMP, STEPLESS EAR, 7/16 DIAMETER	2
32	58-00065-51	GROMMET, 7/8" I.D.	1
33	58-01333-08	SLEEVE, 1/2" FLEXGUARD x 10FT LONG	A / R
34	30-01105-00	CHECK VALVE, FUEL, INLINE	1
35	34-00304-12	SCREW, CAP HXHD, 3/8-16 X 1.50	2
36	34-00945-10	WASHER, LOCK, M10	2
37	34-00944-10	WASHER, FLAT, M10	2
38	34-06051-14	RIVNUT, 3/8-16	2
39	62-10784-00	DECAL, SERVICE PRIMING WILL CALL OUT IN SKINS	1

9.2 FUEL KIT - DAVCO & DAVCO WITH HEATER

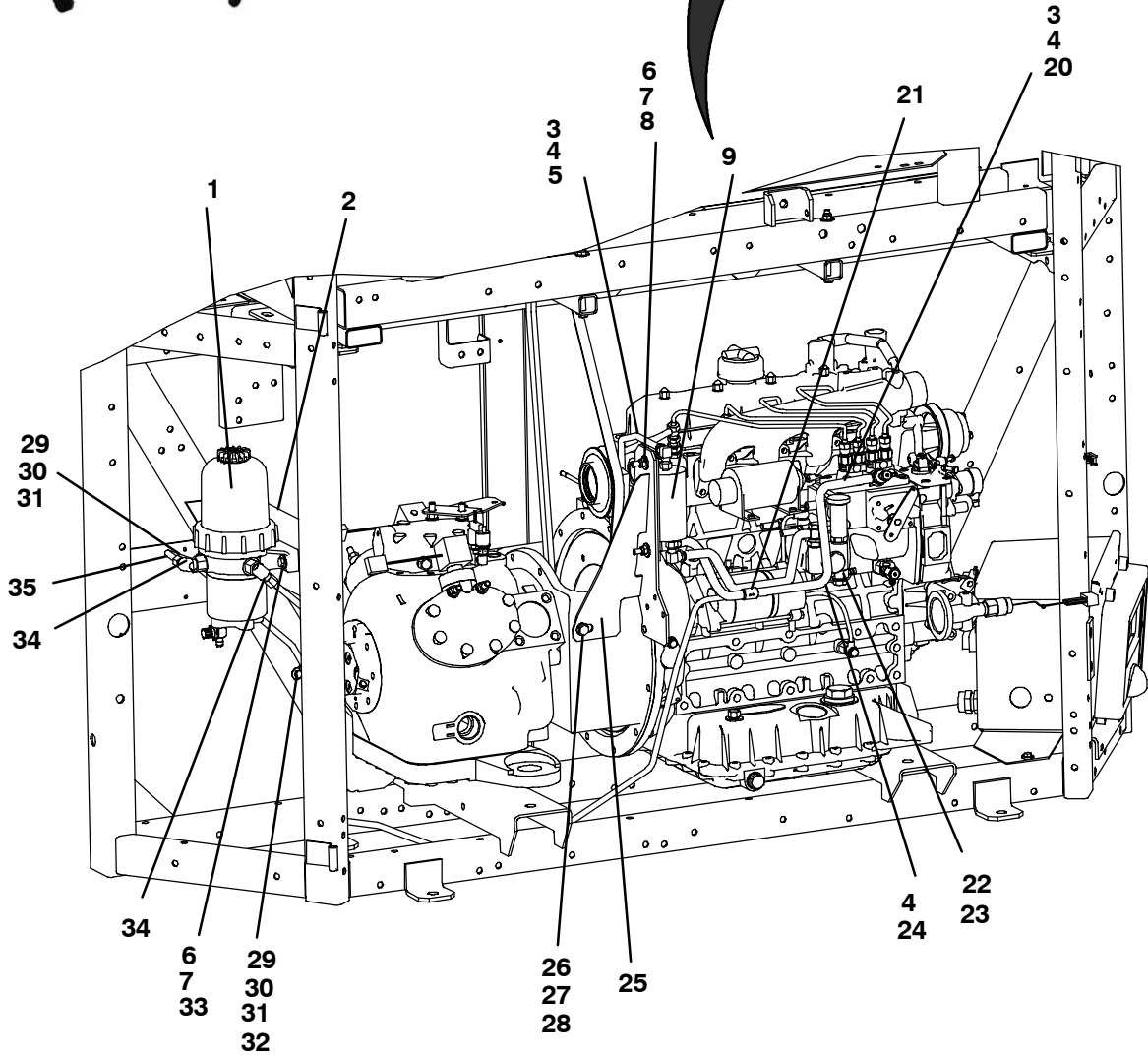
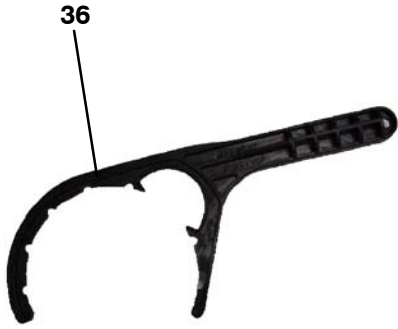
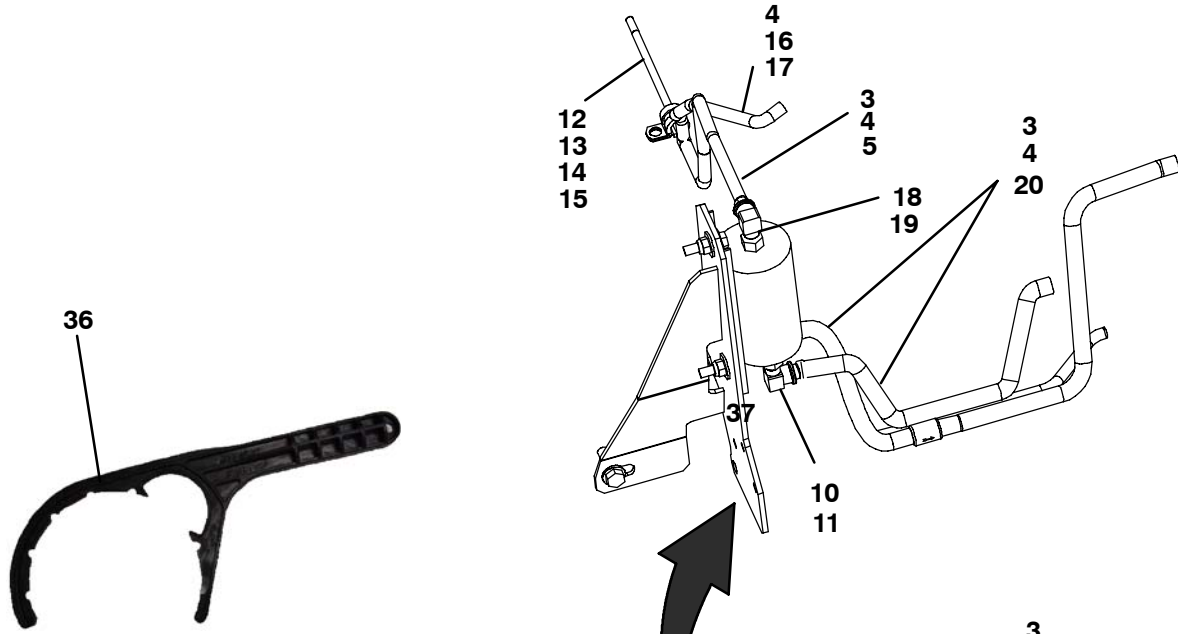

9.2 FUEL KIT DAVCO & DAVCO WITH HEATER

Item	Part Number	Description	Qty
1	30-01106-00	FILTER ASSEMBLY, DAVCO 232 - SEE SECTION 9.2.1	1
	30-01106-01	FILTER ASSEMBLY, DAVCO 232, WITH HEATER SEE SECTION 9.2.1	1
2	68-14771-00	BRACKET, DAVCO FUEL FILTER MOUNTING	1
3	44-01168-00	CLAMP, HOSE, FUEL LINE, 9/16"	6
4	58-01333-08	SLEEVE, 1/2" FLEXGUARD x 10 FT LONG	A / R
5	58-00659-00	HOSE, FUEL, 3/16 ID (SOLD IN 25 FT ROLL)	0
6	34-00361-12	NUT, SELF LOCK, 5/16-18	4
7	34-00366-12	WASHER, PLAIN, 5/16"	8
8	34-00302-10	SCREW, CAP HXHD, 5/16-18 X 1.25	2
9	30-01100-00	FUEL AIR BLEED ASSEMBLY, PRO-CHECK	1
10	40-00420-01	FITTING, HOSE BARB, 5/16 ID X1/4 MPT	2
11	40-00060-02	ELBOW, 90° STREET 1/4 FPT X 1/4 MPT	2
12	58-00858-00	TUBE, SLIT, CORRUGATED, 1/4 ID X 25 FT LONG	A / R
13	79-02305-00	TUBE ASSEMBLY, FUEL - INCLUDES:	1
14	40-01156-00	TEE, FUEL, 3/16" HOSE X 1/4" TUBE X 3/16" HOSE	1
15	44-00293-07	CLAMP, STEPLESS EAR, 15/32" DIAMETER	1
16	44-00293-06	CLAMP, STEPLESS EAR, 7/16 DIAMETER	2
17	58-00915-00	GROMMET, RUBBER, 1/2" ID	1
18	40-00420-00	FITTING, HOSE BARB 3/16 ID X1/8 MPT	1
19	40-00060-01	ELBOW, 90° STREET 1/8 FPT X 1/8 MPT	1
20	58-00658-00	HOSE, FUEL, 5/16 ID (SOLD IN 50 FT ROLL)	A / R
21	30-01105-00	CHECK-VALVE, FUEL, INLINE	1
22	40-01153-00	BANJO, FUEL SYSTEM	1
23	42-01133-00	SEAL, BONDED, M14 (STEEL / RUBBER)	2
24	58-00508-99	TUBE, FUEL, BLACK, .375 OD (SOLD IN 50 FT ROLL)	A / R
25	86-04547-00	BRACKET ASSEMBLY, DAVCO AIRBLEED (PRO-CHECK)	1
26	34-00304-10	SCREW, CAP HXHD, 3/8-16 X 1.25	1
27	34-00944-10	WASHER, FLAT, M10	1
28	34-01249-21	SPACER, M10 X 25 OD X 6 THK	2
29	34-01294-08	SCREW, CAPT. WASH, 1/4-20 X 1.00	6
30	34-06051-06	RIVNUT, 1/4-20	6
31	34-00373-03	CLAMP, TUBE, .38 DIAMETER CUSHION	2
32	58-01333-08	SLEEVE, 1/2" FLEXGUARD x 10 FT LONG	1
33	34-00302-14	SCREW, CAP HXHD, 5/16-18 X 1.75	2
34	40-00342-04	ELBOW, MALE, 3/8 NPT X 3/8 TUBE	2
35	62-04007-00	DECAL, FUEL PRIMING	1
36	07-00423-00	WRENCH, DAVCO FILTER	1
37	44-00102-18	CLAMP, CUSHIONED, .38 DIAMETER	2

9.2.1 DAVCO FUEL FILTER

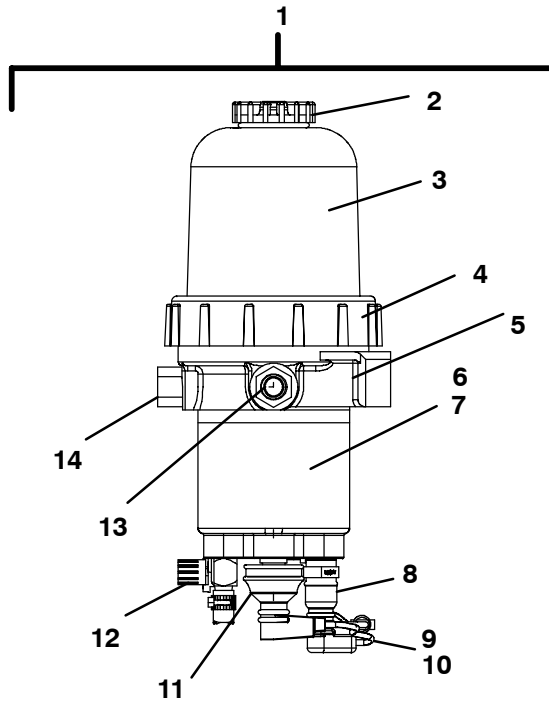

Item	Part Number	Description	Qty
1	30-01106-00	FILTER ASSEMBLY, DAVCO 232 - INCLUDES:	1
	30-01106-01	FILTER ASSEMBLY, DAVCO 232 WITH HEATER - INCLUDES:	1
2	30-01106-22	CAP, VENT, WITH O-RING	1
3	30-01106-20	COVER	1
4	30-01106-21	COLLAR	1
5	30-01097-28	STUD, FILTER MOUNT	1
6	30-01106-23	SPRING, FILTER	1
7	30-01106-25	FILTER ELEMENT, WITH O-RINGS	1
8	30-01106-26	THERMO-SWITCH, 3/8" HEATER ONLY	1
9	30-01106-27	HARNESS, WIRE, THERMO / HEATER BOOT - HEATER ONLY INCLUDES:	1
10	22-50078-01SV	CONNECTOR, 2-WIRE (MATES WITH 22-50078-02SV)	1
11	30-01097-38	HEATER ELEMENT, 12VDC, 150 WATT HEATER ONLY	1
12	30-01097-24	VALVE, DRAIN	1
13	30-01097-27	FITTING, OUTLET, 3/4-16	1
14	30-01106-28	CHECK-VALVE SERVICE KIT, WITH INLET FITTINGS	1

9.3 FUEL HOSE & FITTING - RAIL ONLY

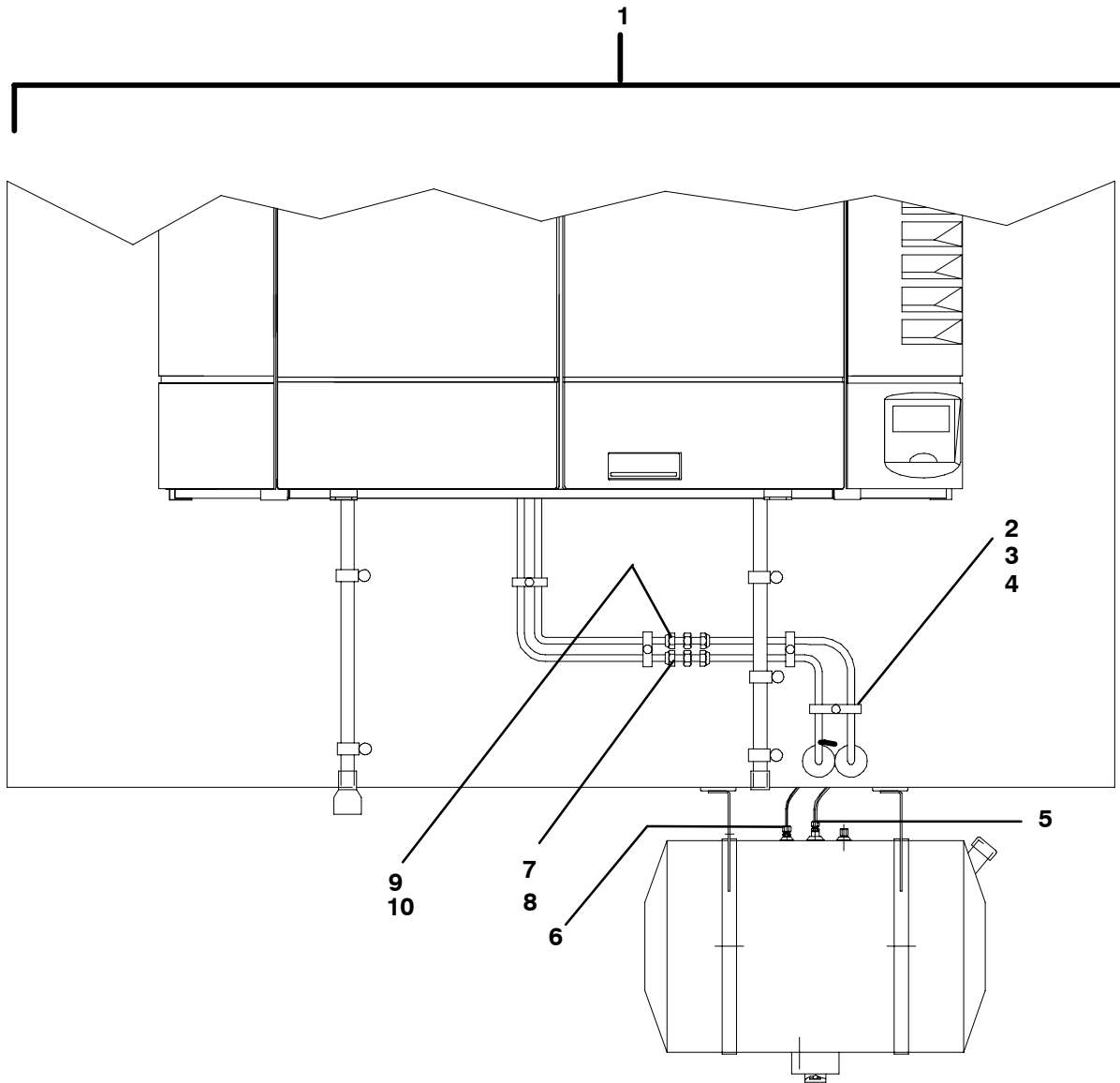

Item	Part Number	Description	Qty
1	76-00566-00	FUEL HOSE AND FITTINGS KIT, RAIL ONLY - INCLUDES:	
2	34-01276-08	SCREW, HX WASHHD, 1/4 X 1.00 SELF-TAPPING	6
3	34-00373-01	CLAMP, TUBE, .25 DIAMETER CUSHION	6
4	34-00373-03	CLAMP, TUBE, .38 DIAMETER CUSHION	6
5	40-00450-01	CONNECTOR, MALE, 3/8 TUBE X 1/4 MPT	1
6	40-00450-00	CONNECTOR, MALE, 1/4 TUBE X 1/4 MPT	1
7	40-00349-00	UNION, COMPRESSION, 1/4" TUBE	1
8	58-00507-00	TUBE, FUEL, BLACK, 1/4 OD (SOLD IN 50 FT ROLL)	35 FT
9	40-00349-01	UNION, COMPRESSION, 3/8" TUBE	1
10	58-00508-99	TUBE, FUEL, BLACK, .375 OD (SOLD IN 50 FT ROLL)	35 FT

10 COOLANT KIT - RUBBER / SILICONE & ECR RUBBER - WITH & WITHOUT SENSOR

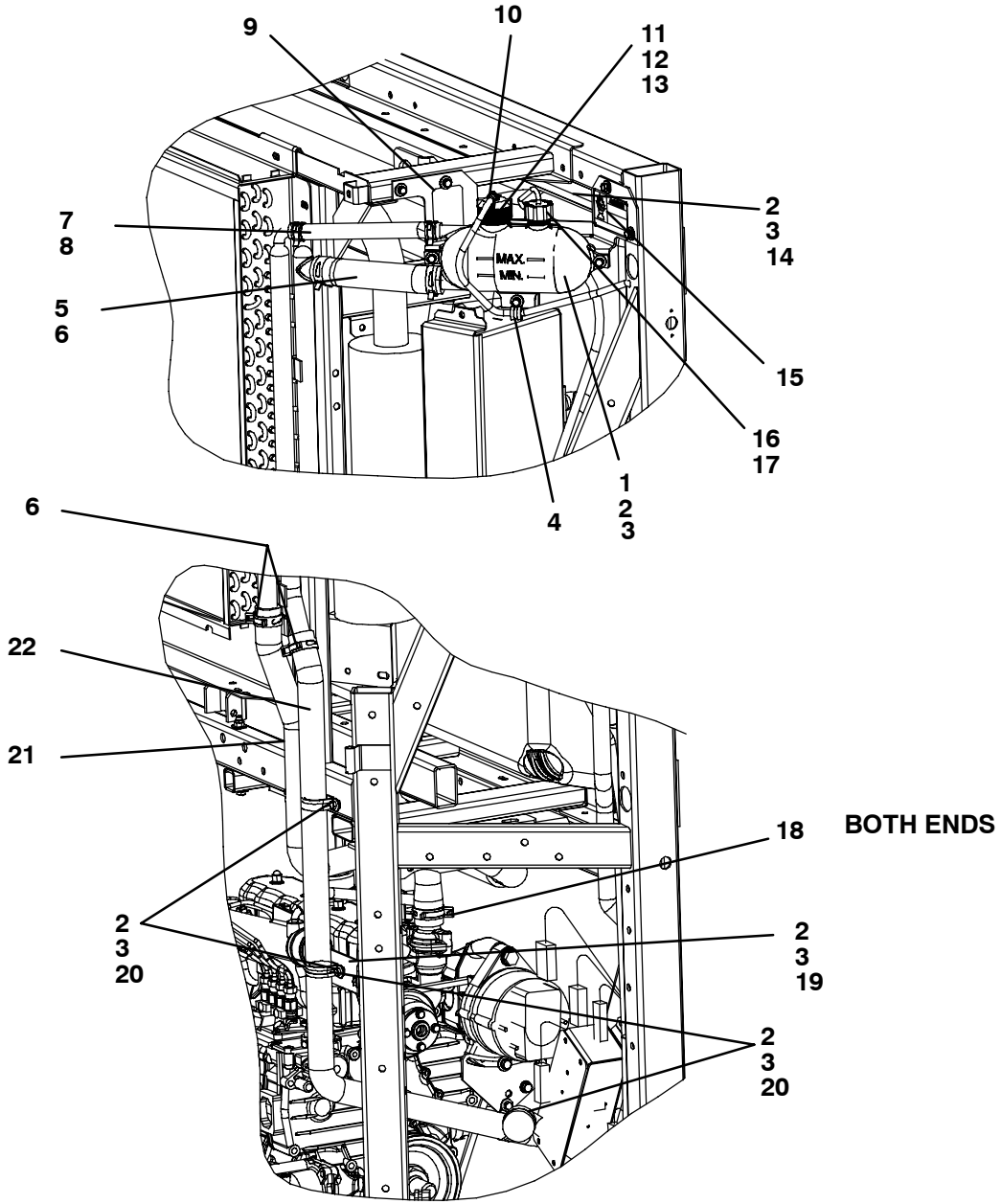

10 COOLANT KIT - RUBBER / SILICONE & ECR RUBBER - WITH & WITHOUT SENSOR

Item	Part Number	Description	Qty
1	58-04661-00	BOTTLE, COOLANT, WITH SENSOR PORT	1
	58-04661-01	BOTTLE, COOLANT, WITHOUT SENSOR PORT	1
2	34-01294-08	SCREW, CAPT. WASH, 1/4-20 X 1.00	11
3	34-06051-06	RIVNUT, 1/4-20	11
4	34-00373-05	CLAMP, TUBE, .50 DIAMETER CUSHION	1
5	58-04223-07	HOSE, COOLANT BOTTLE, 1-1/8" ID X 9.25" L, RUBBER	1
	58-04223-08	HOSE, COOLANT BOTTLE, 1-1/8" ID X 9.25" L, SILICONE	1
	58-04223-09	HOSE, COOLANT BOTTLE, 1-1/8" ID X 9.25" L, ECR RUBBER	1
6	44-01170-36	CLAMP, HOSE, 36 MM (1.41") DIAMETER	4
7	58-04223-10	HOSE, COOLANT BOTTLE, 5/8" ID X 10.25" L, RUBBER	1
	58-04223-11	HOSE, COOLANT BOTTLE, 5/8" ID X 10.25" L, SILICONE	1
	58-04223-12	HOSE, COOLANT BOTTLE, 5/8" ID X 10.25" L, ECR RUBBER	1
8	44-01170-23	CLAMP, HOSE, 23 MM (0.90") DIAMETER	2
9	62-04074-00	DECAL, EXTENDED LIFE COOLANT	1
10	58-04663-00	CAP, COOLANT BOTTLE	1
11	44-00293-06	CLAMP, STEPLESS EAR, 7/16 DIAMETER	1
12	22-04073-00	TUBE, VINYL, 1/4 I.D. (SOLD IN 25 FT ROLLS)	A / R
13	58-00079-00	STA-STRAP, 0-4.00 DIAMETER CABLE	10
14	86-04592-00	BRACKET ASSEMBLY, COOLANT BOTTLE	1
15	62-10793-00	DECAL, CAUTION, RADIATOR FILL	1
16	12-00601-00	SENSOR, COOLANT LEVEL - INCLUDES:	1
17	22-50078-02SV	CONNECTOR, 2-WIRE (MATES WITH 22-50078-01SV)	1
18	44-01170-41	CLAMP, HOSE, 41 MM (1.61") DIAMETER	2
19	68-13638-00	BRACKET, RAD. OUTLET HOSE SUPPORT	1
20	34-00373-70	CLAMP, TUBE, 1.44 DIAMETER CUSHION	4
21	58-04538-00	HOSE, RADIATOR INLET, RUBBER	1
	58-04538-01	HOSE, RADIATOR INLET, SILICONE	1
	58-04538-02	HOSE, RADIATOR INLET, ECR RUBBER	1
22	58-04606-00	HOSE, RADIATOR OUTLET, RUBBER	1
	58-04606-01	HOSE, RADIATOR OUTLET, SILICONE	1
	58-04606-02	HOSE, RADIATOR OUTLET, ECR RUBBER	1

11 AIR CLEANER ASSEMBLY

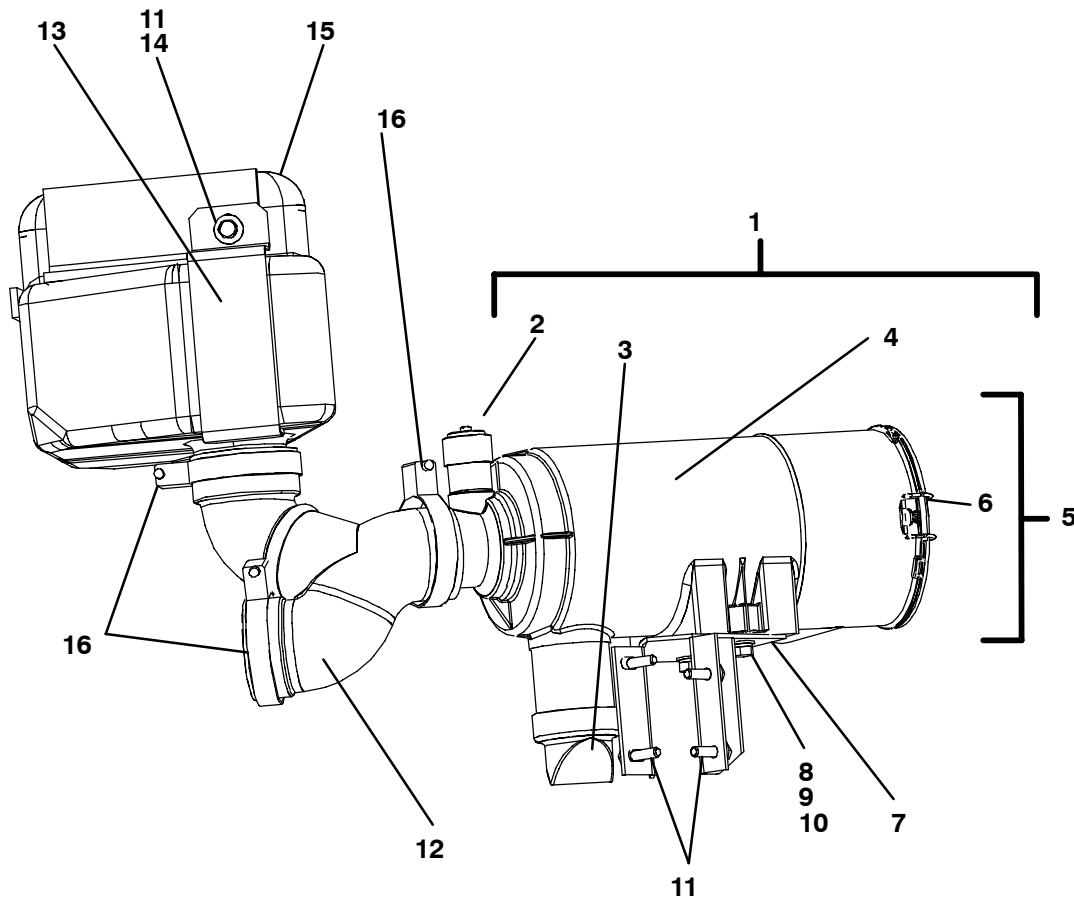

Item	Part Number	Description	Qty
1	30-00471-01	AIR CLEANER ASSEMBLY - INCLUDES:	1
2	30-00328-01	INDICATOR, AIR FILTER (FILTER MINDER)	1
3	30-00471-31	KAZOO, DRAIN	1
4	30-00471-20	FILTER ELEMENT	1
5	30-00471-30	END CAP ASSEMBLY - INCLUDES:	1
6	NSS	CLIPS, AIR CLEANER HOUSING	2
7	86-04661-00	BRACKET, AIR CLEANER	1
8	34-00876-16	SCREW, CAP HXHD, M8 X 15 MM (0.63")	2
9	34-00944-08	WASHER, FLAT, M8	2
10	34-00945-08	WASHER, LOCK, M8 SPRING	2
11	34-01294-08	SCREW, CAPT. WASH, 1/4-20 X 1.00	4/5
12	58-04535-00	HOSE, AIR CLEANER	1
	58-04752-00	HOSE, TEE, AIR CLEANER STEALTH UNITS ONLY	1
13	68-15369-00	BRACKET, RESONATOR STEALTH UNITS ONLY	1
14	34-06061-06	RIVNUT, 1/4-20	1
15	58-04753-00	RESONATOR, INTAKE AIR SOUND DEADENER STEALTH UNITS ONLY	1
16	44-00045-05	CLAMP, HOSE, 2.06-3.00 WORM TYPE	2/3

12 EXHAUST SYSTEM

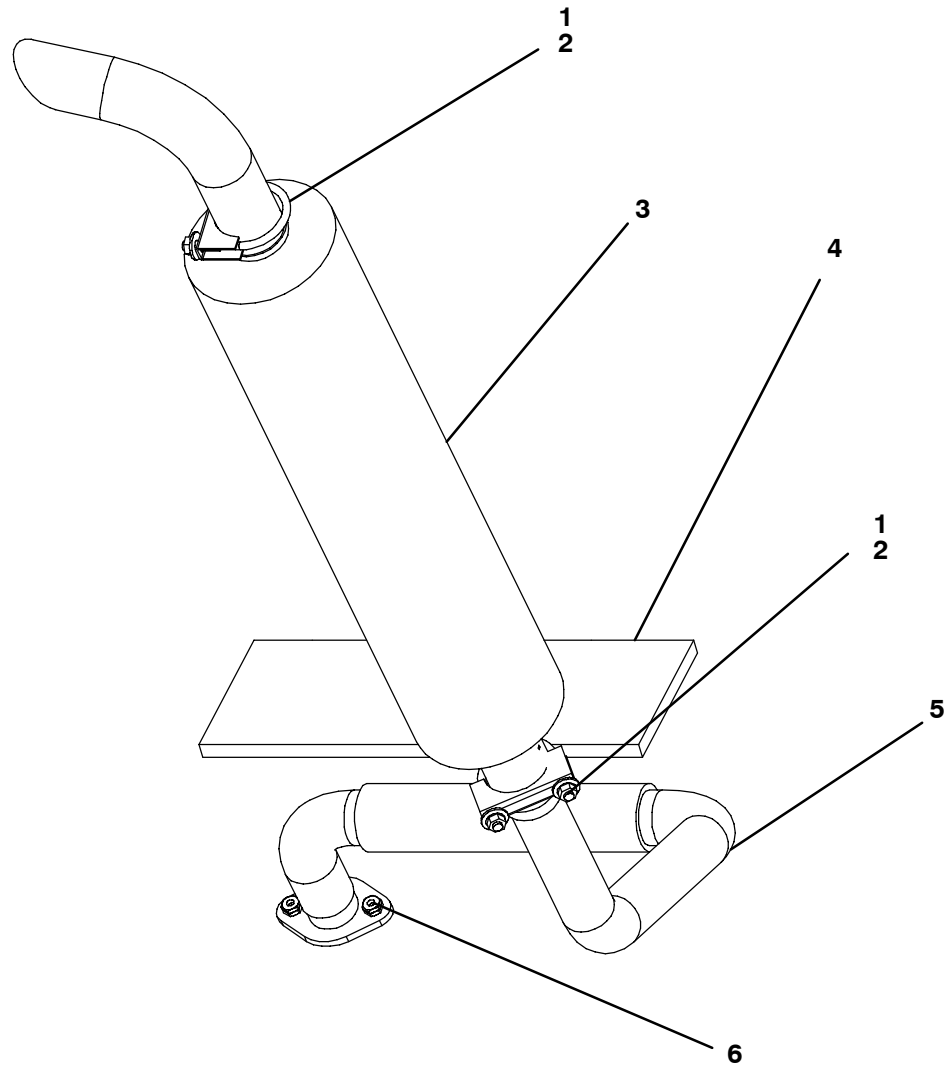

Item	Part Number	Description	Qty
1	30-00175-01	CLAMP, U-BOLT, 5/16-18 X 2.00 DIAMETER	2
2	34-00366-12	WASHER, FLAT, 5/16	4
3	30-00453-01	MUFFLER	1
4	42-01210-01	INSULATION, EXHAUST	1
5	30-00452-01	PIPE, EXHAUST	1
6	34-00932-13	NUT, JAM, 3/8-24 - BRASS	4

13 ELECTRICAL

13.1 HARDWARE AND HARNESSES

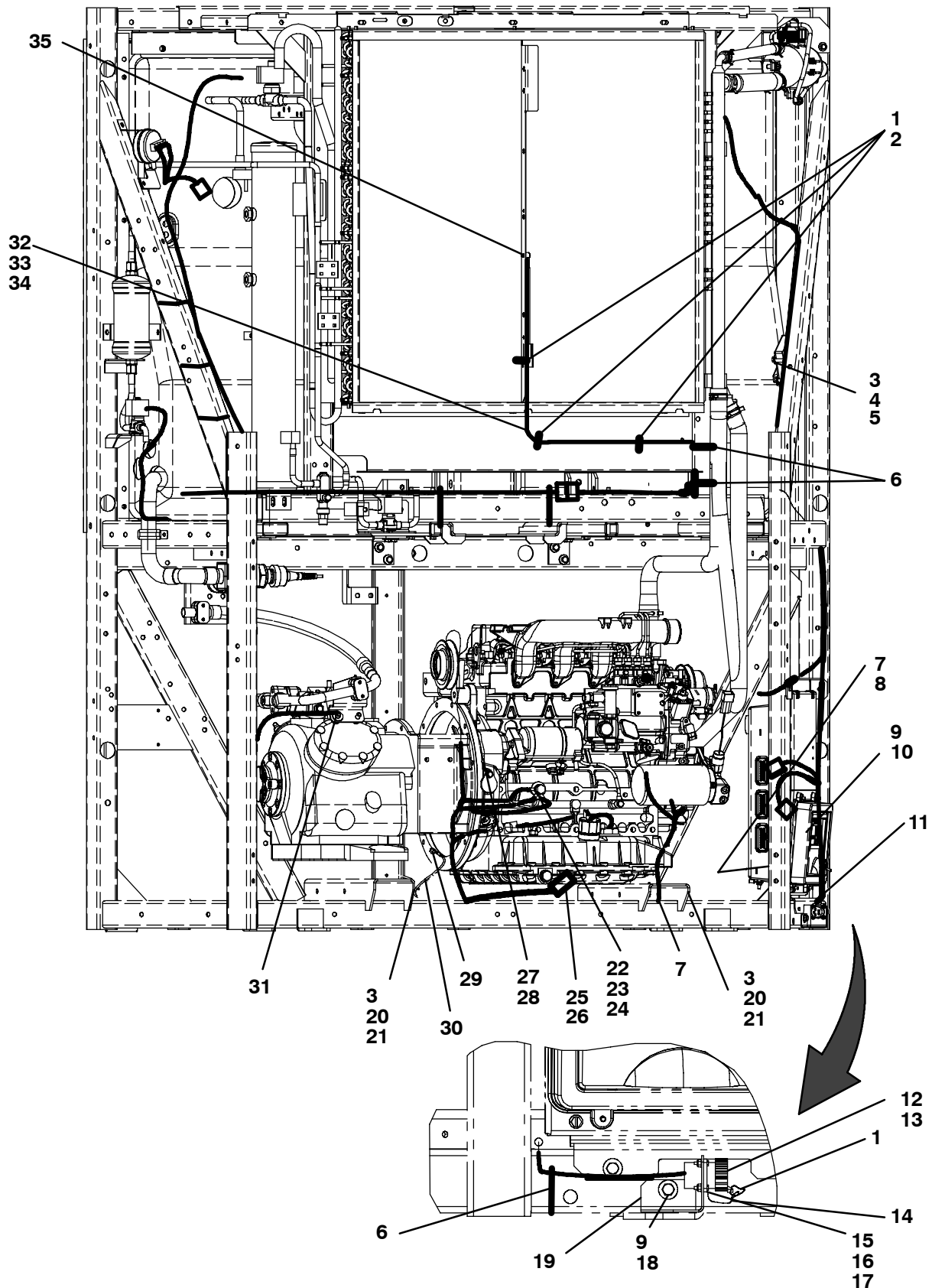

13.1 HARDWARE AND HARNESSSES

Item	Part Number	Description	Qty
1	58-00079-02	STA-STRAP, 0-1.75" DIAMETER CABLE	1
2	44-01042-00	BASE, TY-WRAP	5
3	34-00666-11	NUT, HEX, 1/4-20	2
4	34-06003-12	SCREW, CAP HXHD, 1/4-20 X 1.50	9
5	34-00368-11	WASHER, LOCK, 1/4"	3
6	58-00079-00	STA-STRAP, 0-4.00 DIAMETER CABLE	1
7	58-04523-00	STA-STRAP, 0-2.50 DIAMETER CABLE	1
8	58-04507-00	HOLDER, WIRE TIE	1
9	34-01294-06	SCREW, CAPT. WASH, 1/4-20 X .75	5
10	91-00343-02	CONTROL BOX ASSEMBLY, SEE SECTION 13.2	1
	91-00343-03	CONTROL BOX ASSEMBLY WITH AUTO FRESH AIR (AFAX) SEE SECTION 13.2	1
11	22-04048-01	HARNESS, ENGINE, SEE SECTION 13.3	1
12	22-01660-05	CAP, DUST, (5-PIN INTERROGATOR RECEPTACLE)	1
13	22-01660-03	CONNECTOR / RECEPTACLE, 5-WIRE, INTERROGATOR	1
14	44-01159-00	LANYARD, CONNECTOR CAP	1
15	34-00662-05	WASHER, PLAIN, #4	8
16	34-00667-05	NUT, SELF LOCK, #4-40	4
17	34-06126-08	SCREW, MACH HXHD, #4-40 X .50 LG SLTD	4
18	34-06051-06	RIVNUT, 1/4-20	1
19	68-15129-00	BRACKET, INTERROGATOR PLUG	13
20	34-00372-41	WASHER, LOCK, 1/4 EXT TOOTH	2
21	34-06039-00	NUT, HEX JAM, 1/4-20	2
22	34-00962-25	SCREW, CAP HEXHEAD, M12 X 25 MM (0.98)	1
23	34-00372-45	WASHER, LOCK, 1/2 EXT TOOTH	3
24	34-00829-15	WASHER, PLAIN, 1/2"	2
25	22-04060-00	CONNECTOR ASSY, JUMPER, X2 2500 A/R ONLY - INCLUDES:	3
26	22-50078-01SV	CONNECTOR, 2-WIRE (MATES WITH 22-50078-02SV)	1
27	34-00372-44	WASHER, LOCK, 7/16 EXT TOOTH	1
28	34-06134-07	NUT, HEX, M10 X 1.25	1
29	34-00372-43	WASHER, LOCK, 3/8 EXT TOOTH	1
30	30-00006-00	CABLE, BRAIDED, GROUND	1
31	34-00366-13	WASHER, PLAIN, 3/8	1
32	22-01943-00	HARNESS, ATS - INCLUDES:	1
33	22-50078-01SV	CONNECTOR, 2-WIRE (MATES WITH 22-50078-02SV)	1
34	12-00495-02SV	THERMISTOR, ATS	1
35	58-04478-00	FASTENER, PLASTIC, PUSH-IN	5

13.2 CONTROL BOX

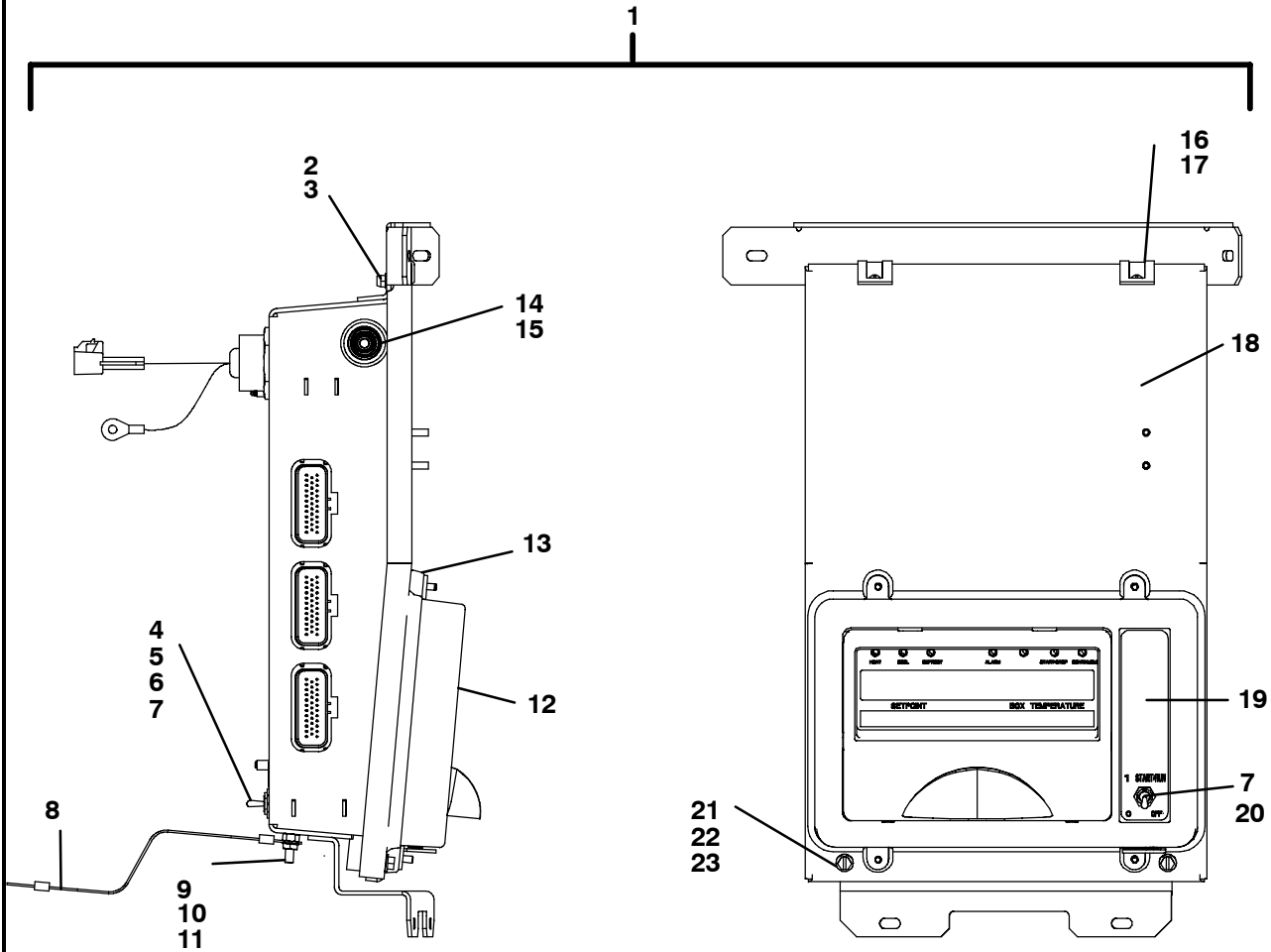

13.2 CONTROL BOX

Item	Part Number	Description	Qty
1	91-00343-02	CONTROL BOX ASSEMBLY - INCLUDES:	1
	91-00343-03	CONTROL BOX ASSEMBLY W/ AUTO FRESH AIR (AFAX) - INCLUDES:	1
2	34-00361-08	NUT, SELF LOCK, 8-32	2
3	34-00366-08	WASHER, PLAIN, #8	2
4	62-10334-00	DECAL, GLOW / CRANK SWITCH	1
5	58-00511-13	WASHER, NYLON, 1/2" ID	1
6	10-01129-16SV	SWITCH, TOGGLE, GLOW / CRANK - INCLUDES:	1
7	66U1-9752	SEAL, PANEL BUSHING	2
8	22-01900-00	CABLE ASSEMBLY, GROUND	1
9	34-00666-11	NUT, HEX, 1/4-20	1
10	34-00372-41	WASHER, LOCK, 1/4 EXT TOOTH	1
11	34-06039-00	NUT, HEX JAM, 1/4-20	1
12	91-00312-02SV	DISPLAY ASSEMBLY, MICRO MODULE - SEE SECTION 13.5	1
13	42-60113-00	GASKET, DISPLAY	1
14	10-00375-01SV	BUZZER, WARNING, WITH O-RING - INCLUDES:	1
15	42-00243-14	O-RING, 1.06 ID X 1.31 OD	1
16	44-00356-00	HINGE, TWO-PIECE PLASTIC	2
17	34-00827-10	SCREW, MACH TRHD, #8-32 X .62	2
18	86-04558-00	DOOR ASSEMBLY, CONTROL BOX	1
19	62-02448-03	DECAL, START / RUN SWITCH	1
20	10-01129-15SV	SWITCH, TOGGLE, ON / OFF - INCLUDES:	1
7	66U1-9752	SEAL, PANEL BUSHING	1
21	34-06265-08	SCREW, CAP HXHD, 1/4-20 X 1.00	2
22	34-01226-00	WASHER, RETAINING .18 ID	2
23	34-06053-04	WASHER, .250 ID	2

13.2 CONTROL BOX (Continued)

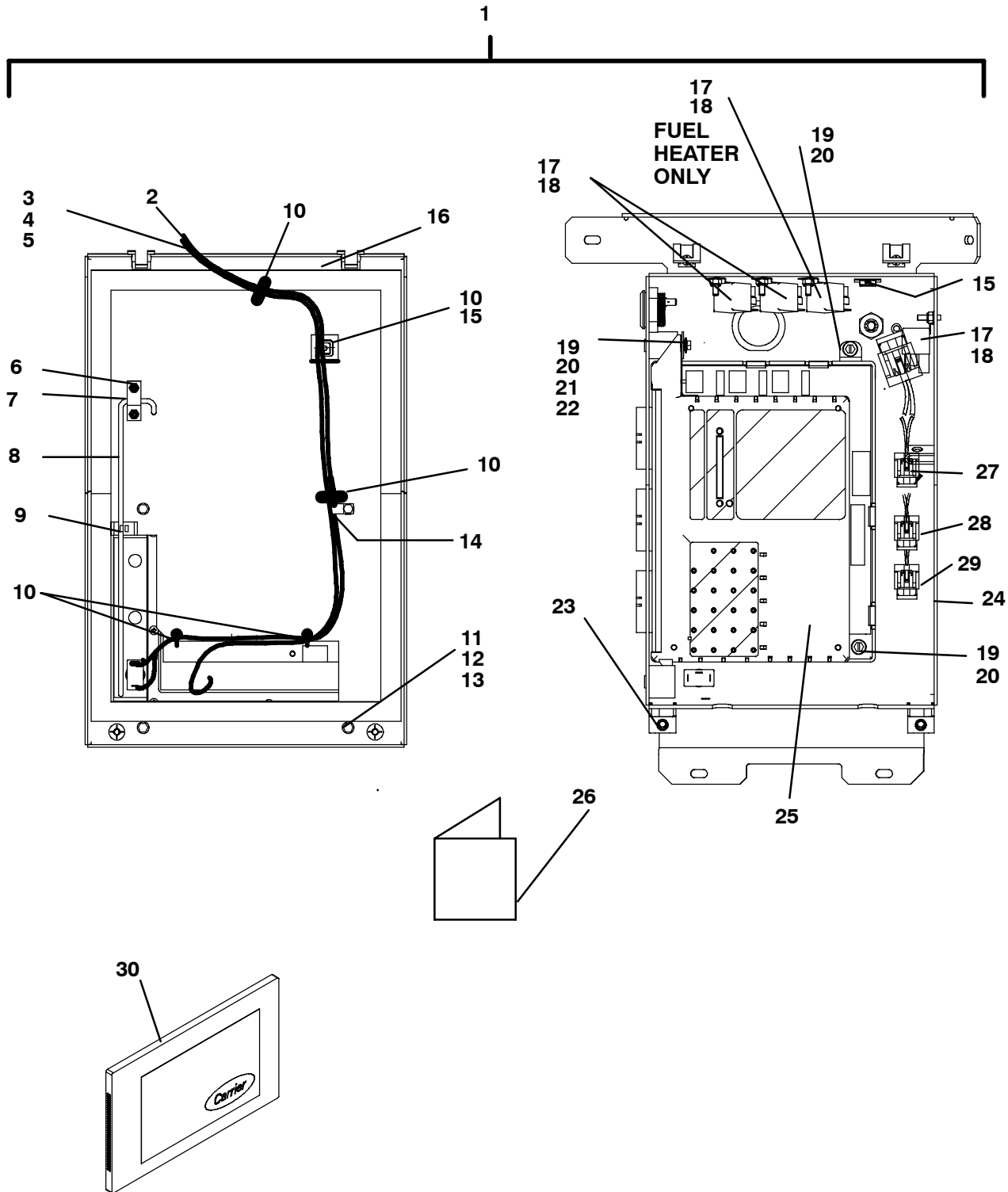

13.2 CONTROL BOX (Continued)

Item	Part Number	Description	Qty
1	91-00343-02	CONTROL BOX ASSEMBLY - INCLUDES:	1
	91-00343-03	CONTROL BOX ASSEMBLY W/ AUTO FRESH AIR (AFAX) - INCLUDES:	1
2	22-04025-00	HARNESS, CONTROL BOX SEE SECTION 13.4	1
	22-04025-01	HARNESS, CONTROL BOX, WITH AFAX SEE SECTION 13.4	1
3	22-04042-00	HARNESS, DISPLAY - INCLUDES:	1
4	22-01622-00	CONNECTOR, 8-WIRE, 6MP	1
5	22-50244-00	CONNECTOR, 8-WIRE, TO DISPLAY BOARD	1
6	34-00361-07	NUT, SELF LOCK, NO. 6-32	2
7	44-00436-00	CLAMP, PROP ROD	1
8	44-00435-00	PROP ROD, CONTROL BOX	1
9	58-04702-00	CLIP, CABLE HOLDER	1
10	58-00079-02	STA-STRAP, 0-1.75" DIAMETER CABLE	7
11	34-01146-05	WASHER, LOCK, M5	4
12	34-01151-05	WASHER, FLAT, M5	4
13	34-60000-25	SCREW, MACH HXHD, M5 X 25 MM (.98) LG	4
14	44-01139-03	CLAMP, CABLE, .375 DIAMETER HARNESS	1
15	58-04697-00	HOLDER, TIE-WRAP, 4-WAY	2
16	42-00552-00	GASKET, CONTROL BOX DOOR	1
17	10-00328-00	RELAY, 70-AMP	2 / 3
18	34-00795-09	NUT, SELF LOCK, 10-32	3 / 4
19	34-06051-04	RIVNUT, 10-32	3
20	34-00917-16	SCREW, HX WASHHD, #10-32 X 1.00 SLTD	3
21	34-00662-20	WASHER, PLAIN, .281 ID	1
22	34-00372-39	WASHER, LOCK, #10 EXT TOOTH	1
23	34-06051-06	RIVNUT, 1/4-20	2
24	86-04494-01	BOX ASSEMBLY (EMPTY)	1
25	12-55438-11/0404	MODULE, LOGIC BOARD	1
26	62-10962-05	SCHEMATIC, X2 2100 AND 2500 A/R	1
27	22-02336-01	FUSE, 20-AMP, FUEL HEATER ONLY	1
28	22-00060-03	FUSE, 15-AMP, FUEL PUMP ONLY	1
29	22-02336-04	FUSE, 10-AMP, FUEL PUMP ONLY	1
30	12-00504-50/0404	PROGRAM CARD	1

13.3 ENGINE HARNESS

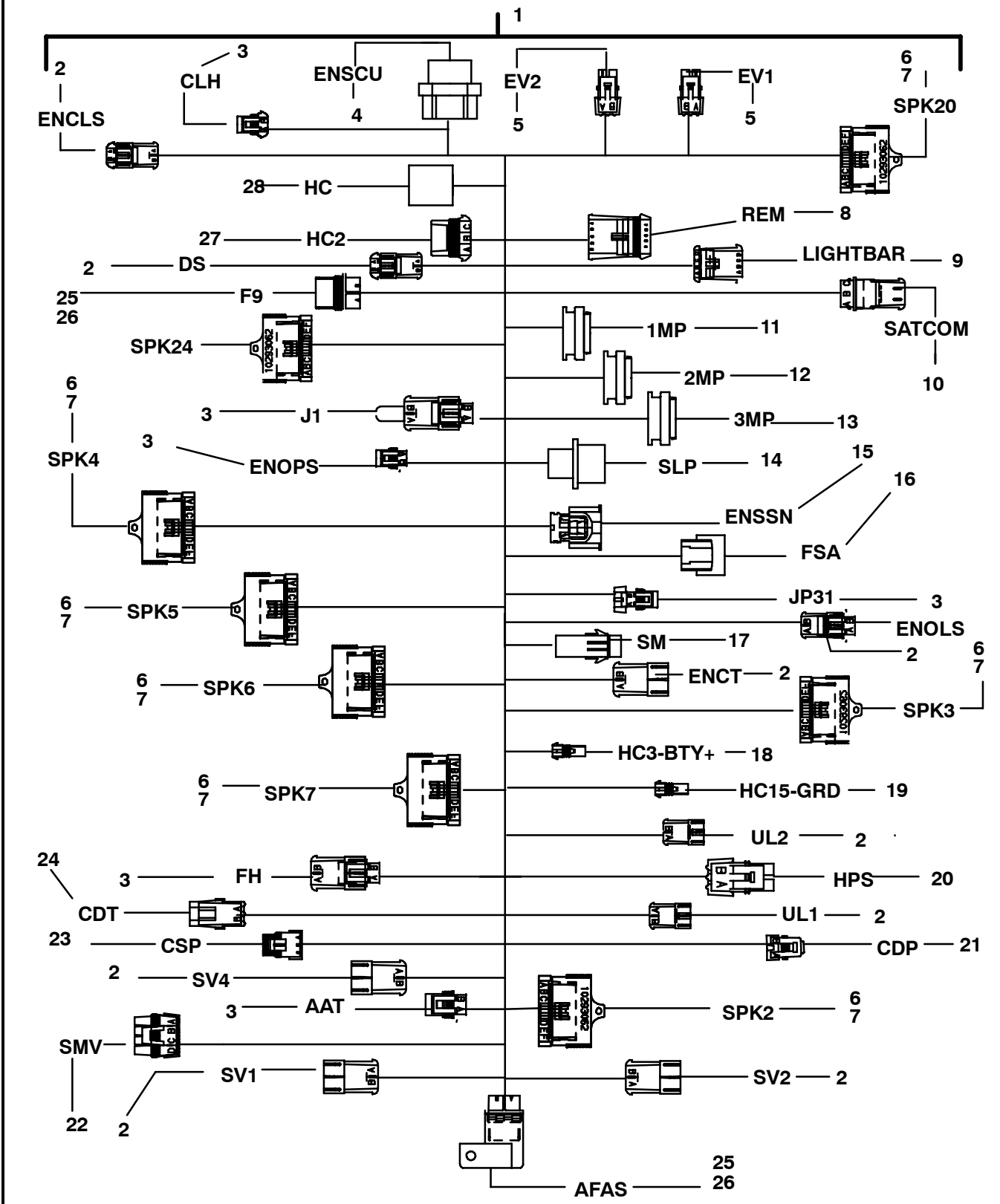

13.3 HARNESSES

Item	Part Number	Description	Qty
1	22-04048-01	HARNESS, ENGINE - INCLUDES:	1
2	22-50078-01SV	CONNECTOR, 2-WIRE, DS, ENCT, ENOLS, SV1, SV2, SV4, UL1, UL2, ENCLS (MATES WITH 22-50078-02SV)	9
3	22-50078-02SV	CONNECTOR, 2-WIRE, CLH, AAT, ENOPS, J1, JP31, FH, (MATES WITH 22-50078-01SV)	6
4	22-50098-61	CONNECTOR, 26-WIRE, ENSCU (MATES W/ 12-00584-00)	1
5	22-50098-57	CONNECTOR, 4-WIRE, EV1, EV2 (MATES WITH 22-50098-58)	2
6	22-50078-82	CONNECTOR, SPLICEPACK, SPK2, SPK3, SPK4, SPK5, SPK6, SPK7, SPK20, SPK24	8
7	22-50078-92	COVER AND BUSSBAR, SPLICEPACK, SPK2, SPK3, SPK4, SPK5, SPK6, SPK7, SPK20, SPK24	8
8	22-50078-45SV	CONNECTOR, 10-WIRE, REM (MATES WITH 22-50078-44SV)	1
9	22-50078-03SV	CONNECTOR, 8-WIRE, LIGHTBAR (MATES WITH 22-50078-04SV)	1
10	22-50078-05SV	CONNECTOR, 3-WIRE, SATCOM (MATES WITH 22-50078-08SV)	1
11	22-50098-17	CONNECTOR, 35-WIRE, NATURAL, 1MP (MATES WITH MICRO)	1
12	22-50098-16	CONNECTOR, 35-WIRE, BLACK, 2MP (MATES W/ MICRO)	1
13	22-50098-18	CONNECTOR, 35-WIRE, GRAY, 3MP (MATES W/ MICRO)	1
14	22-01660-03	CONNECTOR / RECEPTACLE, 5-WIRE, SLP	1
15	22-50098-50	CONNECTOR, 3-WIRE, ENSSN	1
16	22-50098-62	CONNECTOR, 2-WIRE, FSA	1
17	22-50078-30	CONNECTOR, 1-WIRE, SM (MATES WITH 22-50078-31)	1
18	22-50078-20SV	CONNECTOR, 1-WIRE, HC3-BTY+ (MATES WITH 22-50078-06)	1
19	22-50078-21SV	CONNECTOR, 1-WIRE, HC15-GRD (MATES WITH 22-50078-07SV)	1
20	22-01585-00SV	CONNECTOR, 2-WIRE, HPS (MATES W/ 22-02382-00SV)	1
21	22-02448-00SV	CONNECTOR, 3-WIRE, CDP	1
22	22-01585-04	CONNECTOR, 4-WIRE, SMV (MATES WITH 22-02392-03)	1
23	22-01586-00	CONNECTOR, 3-WIRE, CSP (MATES WITH 22-50098-60)	1
24	22-02392-00SV	CONNECTOR, 2-WIRE, CDT (MATES W/ 22-01585-00SV)	1
25	22-50078-22SV	FUSE HOLDER AND COVER ASSY, F9, AFAS - INCLUDES:	2
26	22-02336-03	FUSE, 3-AMP.	1
27	22-50078-87SV	CONNECTOR, 3-WIRE, HC2 (MATES W/ 22-50078-86SV)	1
28	22-50099-06	CONNECTOR, 19-WIRE, HC (MATES WITH 22-50098-10)	1

13.4 CONTROL BOX HARNESS

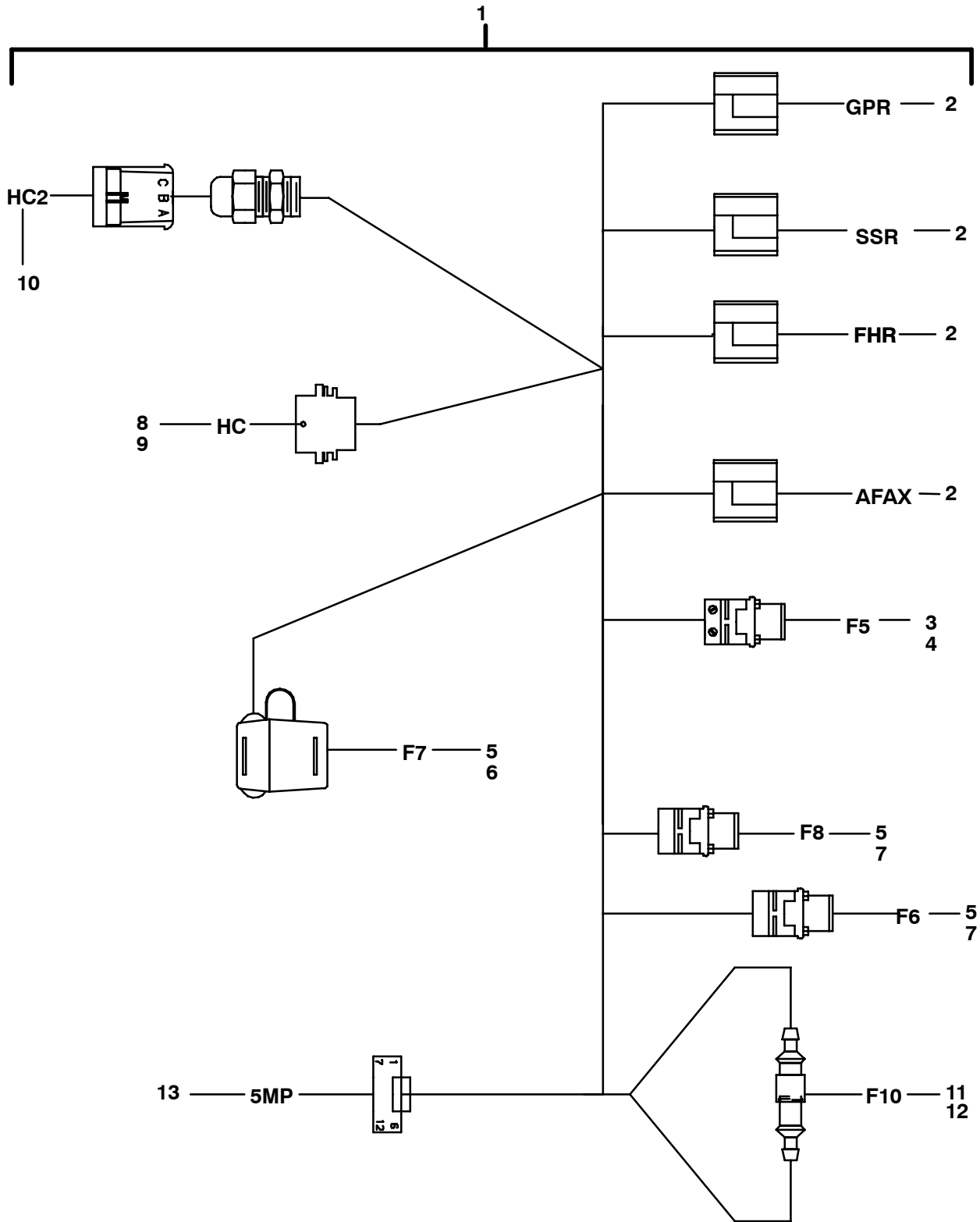

13.4 CONTROL BOX HARNESS

Item	Part Number	Description	Qty
1	22-04025-00	HARNESS, CONTROL BOX - INCLUDES:	1
	22-04025-01	HARNESS, CONTROL BOX, WITH AFAX - INCLUDES:	1
2	22-50078-18	SOCKET, RELAY, GPR, SSR, FHR, AFAX (-01 ONLY), (USE 22-50078-18A, -18B TERMINALS)	3 / 4
3	22-50078-61SV	FUSE HOLDER AND COVER ASSEMBLY, MAXI-FUSE, F5	1
4	22-02336-09	FUSE, 80-AMP, MAXI-FUSE, F5	1
5	22-02338-05	FUSE HOLDER, IN-LINE, F6, F7, F8	3
6	22-02336-21	FUSE, 5-AMP, F7	1
7	22-02336-06	FUSE, 15-AMP, F6, F8	1
8	22-50098-10	CONNECTOR, 19-WIRE, HC (MATES WITH 22-50099-06)	1
9	22-50098-24	GASKET, HC CONNECTOR	1
10	22-50078-86SV	CONNECTOR, 3-WIRE, HC2 (MATES W/ 22-50078-87SV)	1
11	22-01661-00	FUSE HOLDER, IN-LINE, F10 (-01 ONLY)	0 / 1
12	22-00060-35	FUSE, 10-AMP, F10 (-01 ONLY)	0 / 1
13	22-01662-01	CONNECTOR, 12-WIRE, 5MP	1

13.5 ADVANCE MICROPROCESSOR ASSEMBLY - DISPLAY MODULE

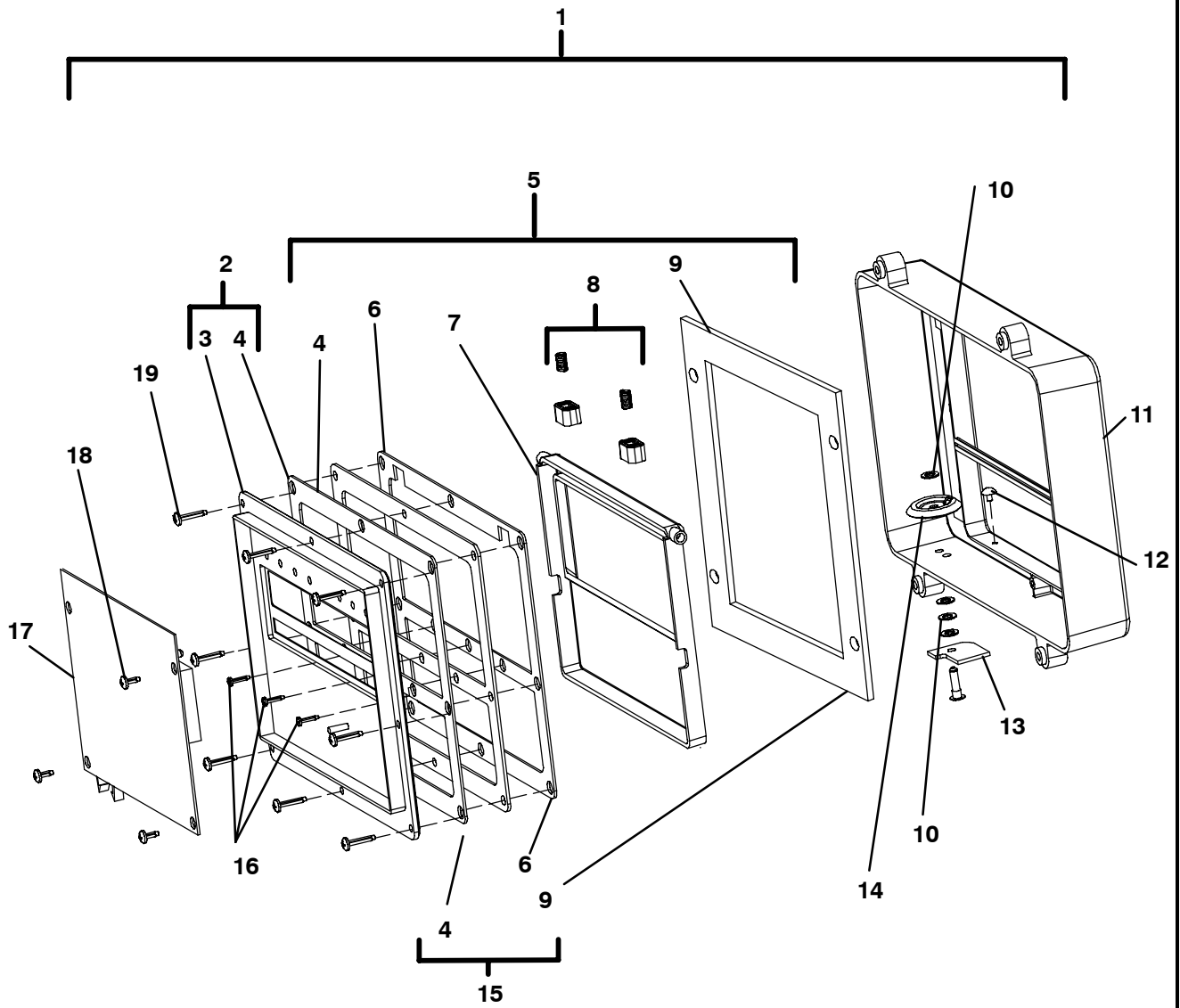

13.5 ADVANCE MICROPROCESSOR ASSEMBLY - DISPLAY MODULE

Item	Part Number	Description	Qty
1	91-00312-02SV	DISPLAY ASSEMBLY, MICRO MODULE - INCLUDES:	1
2	12-00450-00SV	KEY PAD ASSEMBLY - INCLUDES:	1
3	58-04340-00	SUPPORT, KEYPAD MICRO DISPLAY	1
4	42-00405-00	GASKET, MICRO DISPLAY MODULE	1
5	58-04341-02SV	DOOR ASSEMBLY, MICRO DISPLAY - INCLUDES:	1
6	42-00396-00	GASKET, MICRO DISPLAY MODULE	1
7	58-04341-01SV	WINDOW KIT, KEYPAD DOOR	1
8	58-04344-01SV	LATCH, DETENT AND SPRING ASSEMBLY	2
9	42-00406-00	GASKET, BEZEL TO BRACKET	1
4	42-00405-00	GASKET, MICRO DISPLAY MODULE	1
10	34-00829-09	WASHER, PLAIN, # 10	4
11	58-04339-00	BEZEL, MICRO, DISPLAY MODULE	1
12	58-04385-00	PLUG, HOLE, .125 - .130D	2
13	58-04657-00	DEFLECTOR, MOISTURE	1
14	58-00660-00	WASHER, CONDENSATE DRAIN	1
15	58-04342-00SV	WINDOW, MICRO DISPLAY MODULE - INCLUDES:	1
9	42-00406-00	GASKET, BEZEL TO BRACKET	1
4	42-00405-00	GASKET, MICRO DISPLAY MODULE	1
6	42-00396-00	GASKET, MICRO DISPLAY MODULE	1
16	34-06129-06	SCREW, TF PNHD, # 6-19 X 0.38L	3
17	12-00439-02RP	DISPLAY BOARD ASSEMBLY, MICRO	1
18	34-06196-10	SCREW, TF PNHD, M4.2 X 1.4 X 9.5 LG	4
19	34-06196-11	SCREW, TF PNHD, M4.2 X 1.4 X 19 LG	8

14 BATTERY AND ANTI-THEFT OPTION

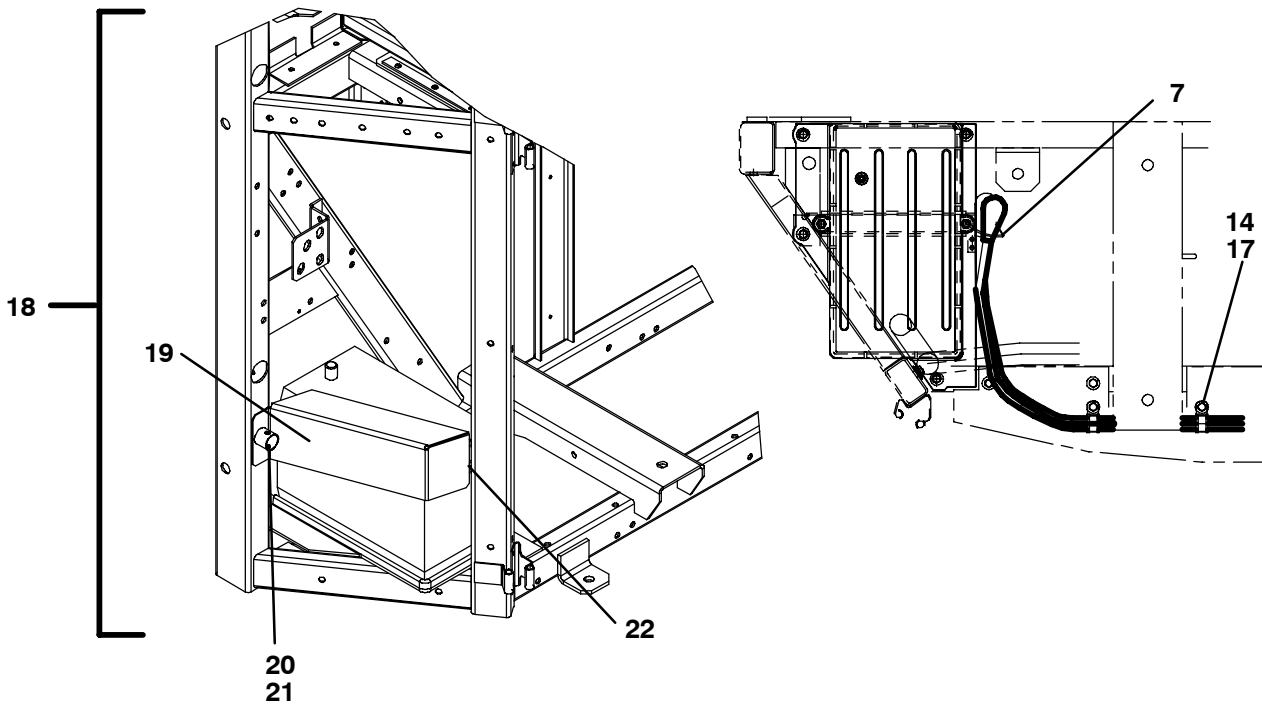
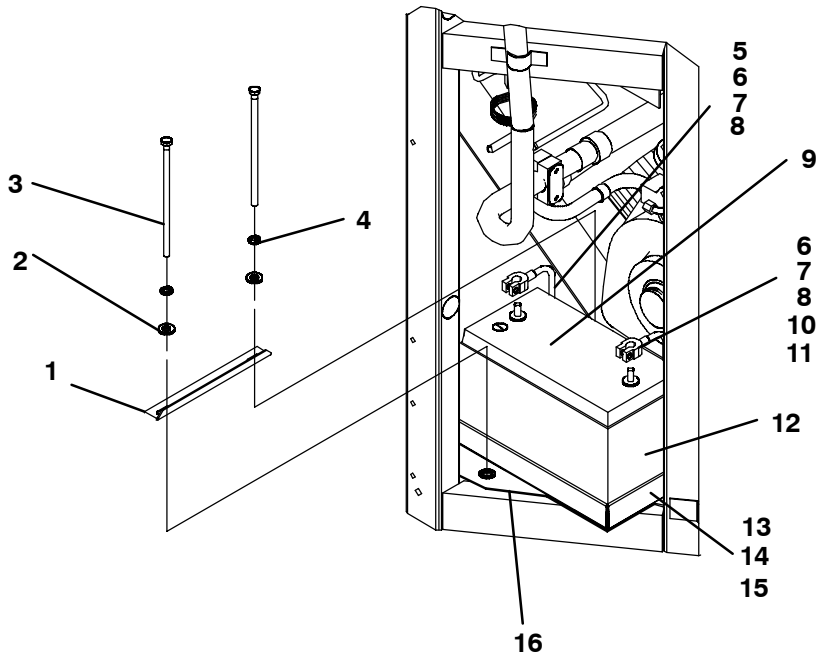

14 BATTERY AND ANTI-THEFT OPTION

Item	Part Number	Description	Qty
1	68-11596-00	ANGLE, BATTERY HOLD-DOWN	1
2	34-00662-12	WASHER, PLAIN, 5/16	2
3	34-01247-80	SCREW, CAP, HEX HEAD, 5/16-18 X 10.00 LG	2
4	34-00663-12	LOCKWASHER, 5/16 - SST	2
5	22-01633-01	BATTERY CABLE, NEGATIVE - POST TYPE	1
	22-01633-11	BATTERY CABLE, NEGATIVE - SCREW TYPE	1
6	58-00079-00	STA-STRAP, 0-4.00 DIAMETER CABLE	8
7	58-00079-02	STA-STRAP, 0-1.75" DIAMETER CABLE	4
8	58-00858-00	TUBE, SLIT, CORRUGATED, 1/4 ID X 25 FT. LONG	A / R
9	62-02139-01	DECAL, WARNING DISCONNECT BATTERY	1
10	22-01633-00	BATTERY CABLE, POSITIVE - POST TYPE	1
	22-01633-10	BATTERY CABLE, POSITIVE - SCREW TYPE	1
11	58-01333-08	SLEEVE, 1/2" FLEXGUARD X 10 FT LONG	1
12	PL	BATTERY, 12-VOLT	1
13	58-01335-00	TRAY, BATTERY, PLASTIC	1
14	34-01294-08	SCREW, CAPT WASH, 1/4-20 X 1.00	1
15	34-00366-13	WASHER, PLAIN, 3/8"	4
16	68-08030-00	BRACKET, BATTERY TRAY MOUNTING	1
17	44-00102-06	CLAMP, CUSHIONED, .88 DIAMETER	2
18	76-00561-00	KIT, ANTI-THEFT BATTERY BRACKET - INCLUDES:	1
19	86-03061-00	BRACKET ASSEMBLY	1
20	34-06051-11	RIVNUT, 5/16-18	1
21	34-00919-08	SCREW, HX WASHHD, 5/16-18 X 1.00	1
22	58-00065-76	GROMMET, .38 I.D. X .62 O.D.	2
23	42-00183-22	TRIM, FLEXIBLE (SOLD IN 25 FT ROLL)	A/R

15 DECALS

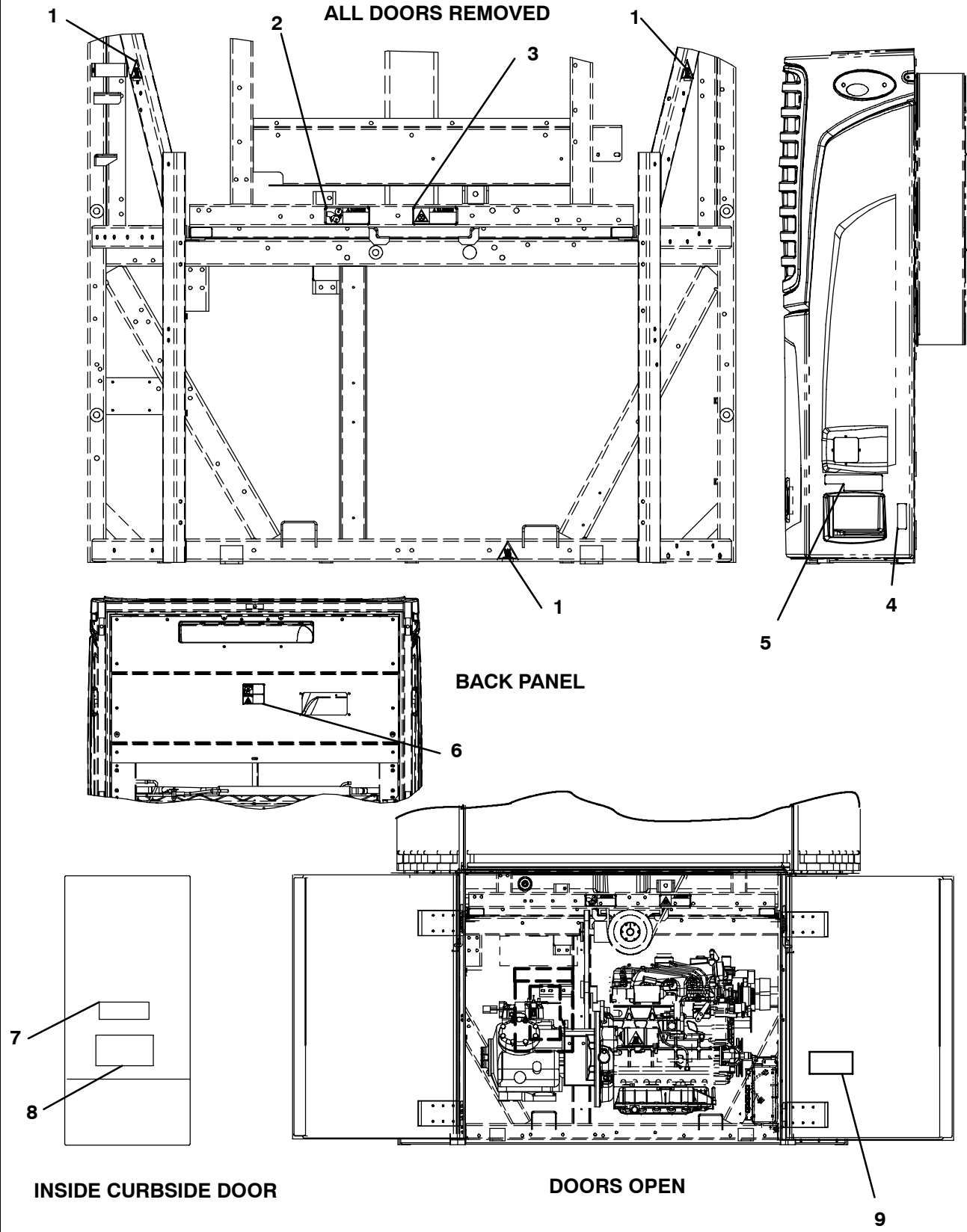

15 DECALS

Item	Part Number	Description	Qty
1	62-03958-00	DECAL, WARNING, HEAT HAZARD	3
2	62-02144-03	DECAL, DANGER, BELT ROTATION	1
3	62-02146-02	DECAL, WARNING, AUTO START	1
4	62-02450-00	DECAL, WARNING, AUTO START	1
5	62-04759-02	DECAL, LOGO, X2-2100A	1
	62-04759-03	DECAL, LOGO, X2-2100R	1
	62-04759-04	DECAL, LOGO, X2-2500A	1
	62-04759-05	DECAL, LOGO, X2-2500R	1
6	62-02509-00	DECAL, WARNING, BEWARE OF FAN AND A / S	1
7	62-02505-00	DECAL, CAUTION, BATTERY COVER	1
8	62-02139-01	DECAL, WARNING, DISCONNECT BATTERY	1
9	62-02140-00	DECAL, SERVICE ACTION LINE	1

16 PACKAGING

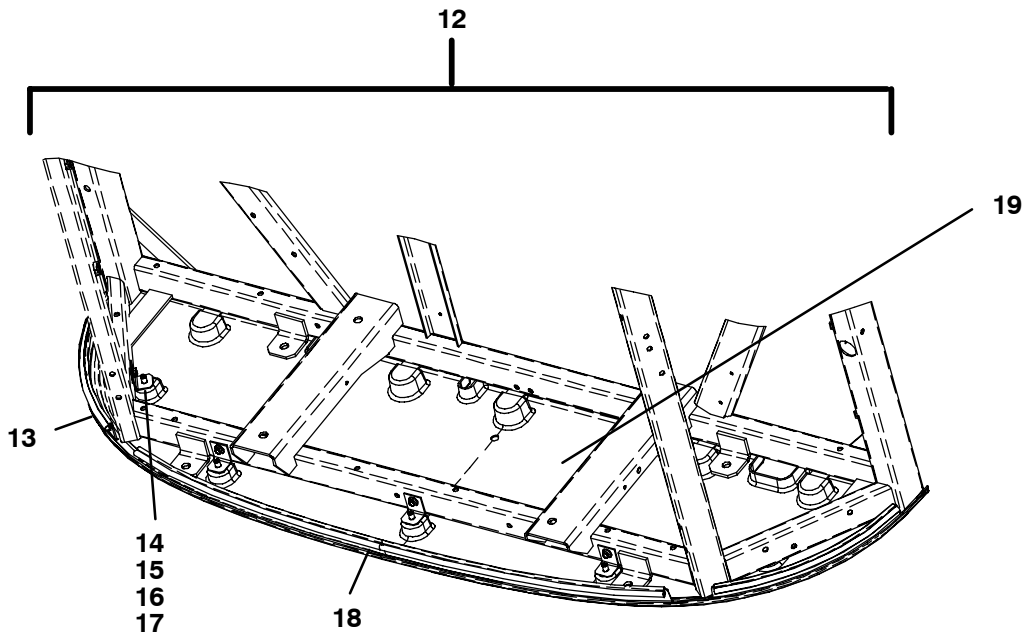
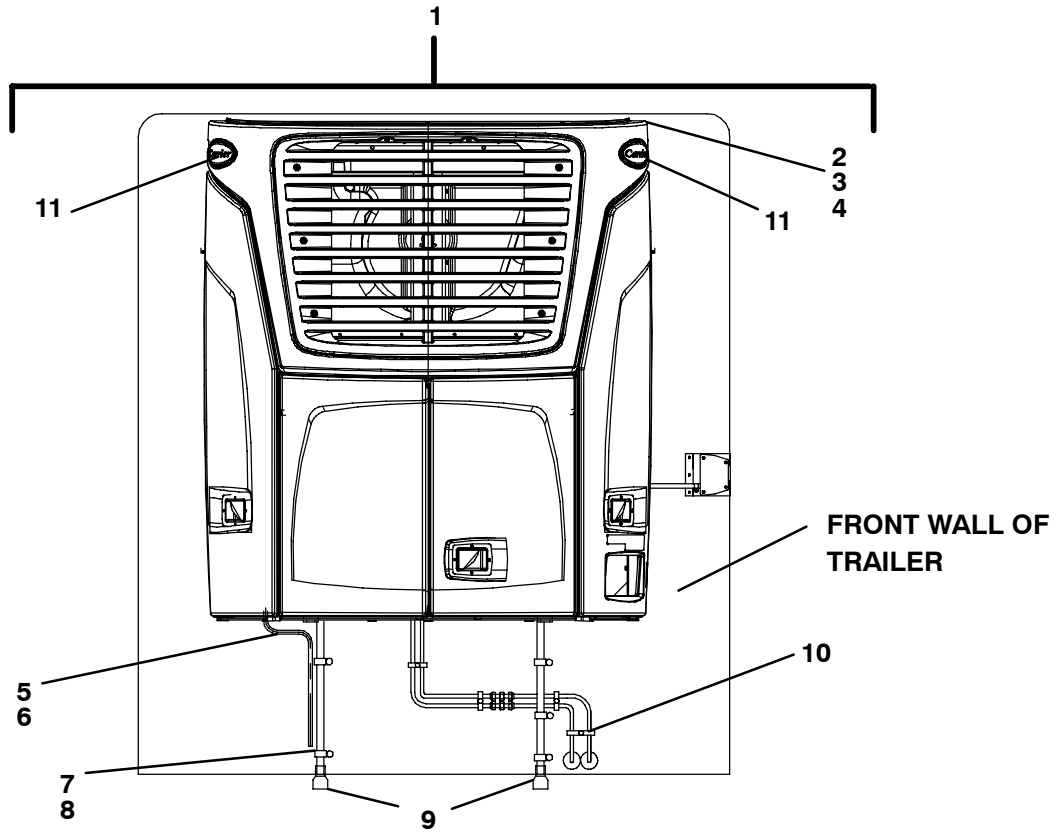

16 PACKAGING

Item	Part Number	Description	Qty
1	76-00510-25	INSTALLATION KIT, UNIT - INCLUDES:	1
2	34-00361-15	NUT, SELF LOCK, 1/2-13	8
3	34-00588-15	WASHER, PLAIN, 1/2 SAE .095 THK	8
4	58-00616-16	PLUG, HOLE, 1.50 DIAMETER X .12 PANEL	9
5	44-00045-26	CLAMP, HOSE, .31-.88 WORM	1
6	58-01337-00	HOSE, 3/8 ID	A / R
7	34-00172-05	CLAMP, HALF, 1.00 DIAMETER	4
8	34-01276-08	SCREW, HEX WASHER HEAD, 1/4 X 1.00 SELF TAPING	4
9	58-00253-01	KAZOO, DRAIN HOSE FITTING	2
10	58-00079-02	STA-STRAP	A / R
11	62-11144-00	DECAL, CARRIER	2
12	76-00796-00	INSTALL KIT, BOTTOM PANEL - INCLUDES:	1
13	42-00264-14	SEAL, TRIM, BLACK, 15.5" L	2
14	34-01294-06	SCREW, CAPT WASH, 1/4-20 X .75	5
15	34-06051-06	RIVNUT, 1/4-20	5
16	34-06025-06	SCREW, HX WASHHD, 1/4-20 X .75 LG.	5
17	68-15153-00	ANGLE, BOTTOM PANEL MOUNTING	5
18	42-00264-13	SEAL, TRIM, BLACK, 48" L	1
19	58-04726-00	COVER, BOTTOM, PLASTIC	1

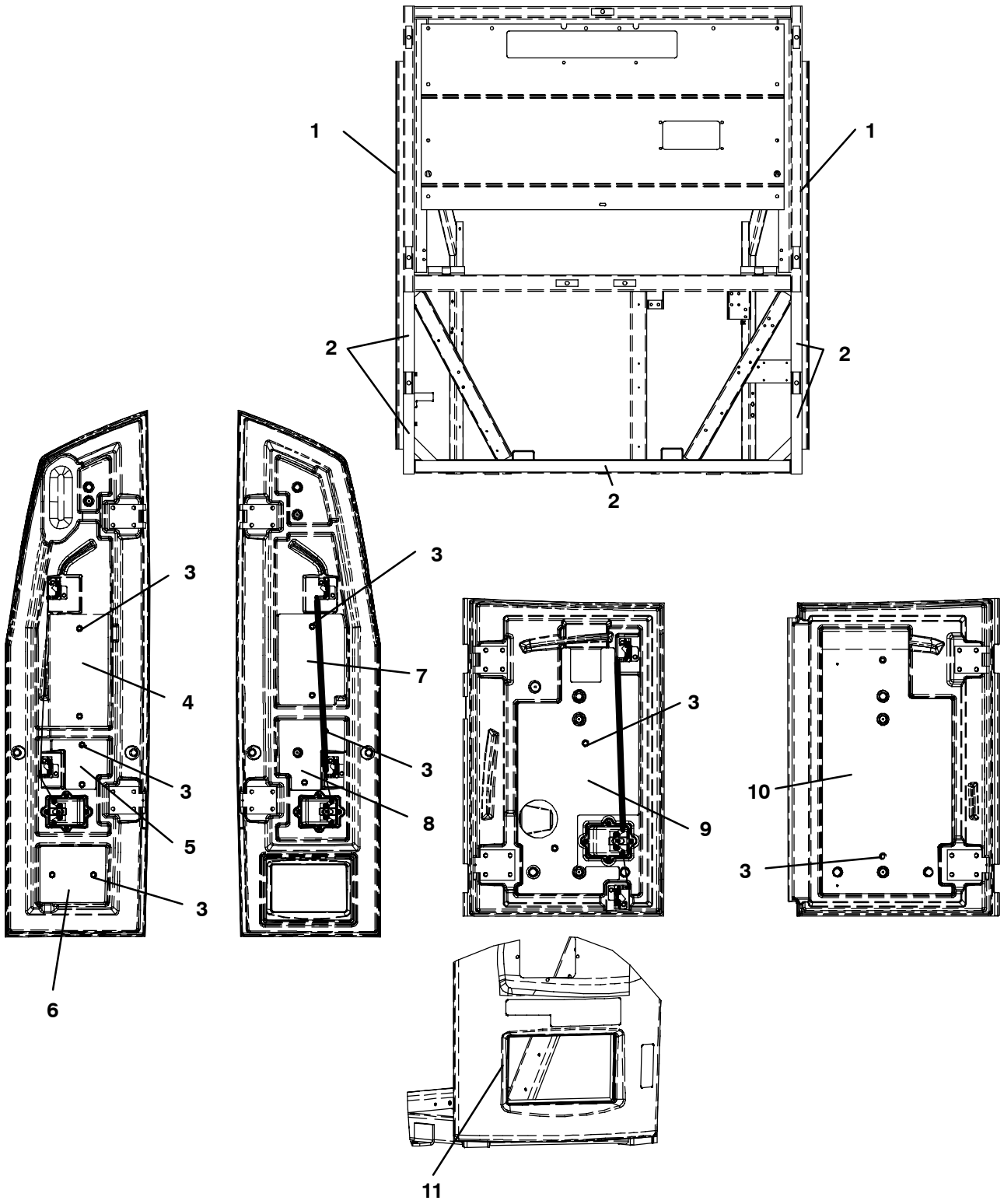

17 LOW-NOISE

Item	Part Number	Description	Qty
1	42-00692-00	SEAL, "D" CROSS SECTION, 70" L	2
2	42-00584-00	GASKET, SEAL, FRAME (SOLD PER FOOT)	A / R
3	58-01214-00	PLUG, RACHET, BLACK	16
4	42-00680-00	INSULATION, SOUND, CS OUTER DOOR, UPPER	1
5	42-00679-00	INSULATION, SOUND, CS OUTER DOOR, MIDDLE	1
6	42-00678-00	INSULATION, SOUND, CS OUTER DOOR, LOWER	1
7	42-00677-00	INSULATION, SOUND, RS OUTER DOOR, UPPER	1
8	42-00675-00	INSULATION, SOUND, RS OUTER DOOR, LOWER	1
9	42-00674-00	INSULATION, SOUND, RS FRONT DOOR	1
10	42-00673-00	INSULATION, SOUND, CS FRONT DOOR	1
11	42-00264-04	SEAL, TRIM, BLACK (SOLD PER FOOT)	A / R

18 FIELD INSTALLED KITS

18.1 BUMPERS

18.1.1 MICRO BUMPER AND BOTTOM PANEL KITS

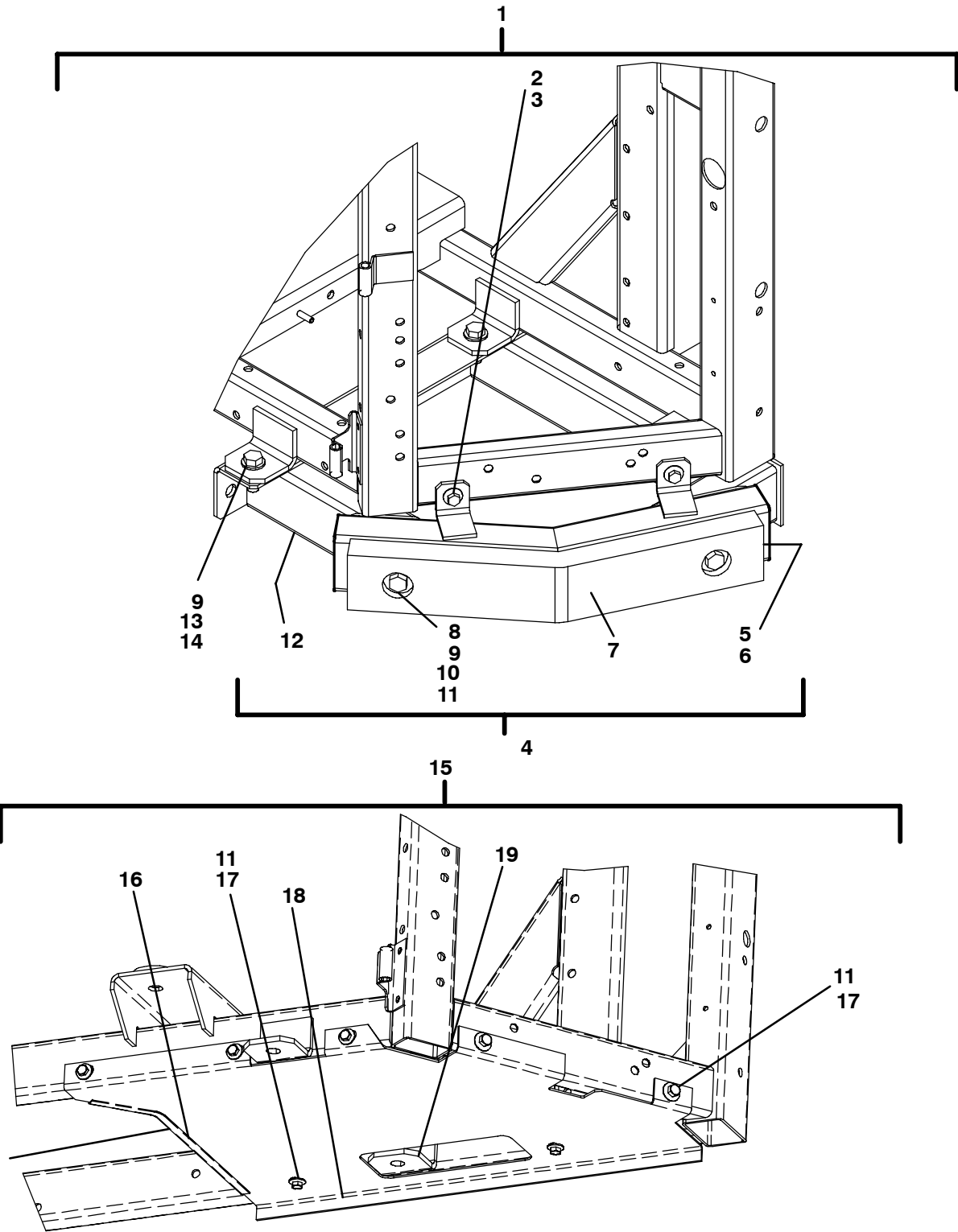

18.1 MICRO BUMPER AND BOTTOM PANEL KITS

Item	Part Number	Description	Qty
1	76-00559-00	BUMPER KIT, MICRO, STAND ALONE - INCLUDES:	1
2	34-00919-08	SCREW, HX WASHHD, 5/16-18 X 1.00" L	2
3	34-06051-10	RIVNUT, 5/16-18	2
4	79-02343-00	BUMPER ASSEMBLY, MICRO - INCLUDES:	1
5	58-04099-04	PLUG, RUBBER, 1.737 X 2.737 RECT.	2
6	86-03054-00	FRAME ASSEMBLY, MICRO BUMPER	1
7	58-01372-01	BUMPER, RUBBER, 1.25 X 3.00"	1
8	34-00366-15	WASHER, PLAIN, 1/2"	2
9	34-00678-12	SCREW, CAP HXHD, 1/2-13 X 1.50" L	2
10	34-00918-08	SCREW, HX WASHHD, 1/4-20 X 1.00" L	2
11	34-06051-06	RIVNUT, 1/4-20	2
12	86-03055-00	PLATE ASSEMBLY, NUT, MICRO BUMPER	2
13	34-00361-15	NUT, SELF LOCK, 1/2-13	2
14	34-00588-15	WASHER, PLAIN, 1/2"	4
9	34-00678-12	SCREW, CAP HXHD, 1/2-13 X 1.50" L	2
15	76-00535-01	MICRO BOTTOM PANEL KIT - INCLUDES:	1
16	42-00183-00	TRIM, FLEXIBLE (SOLD IN 25 FT ROLL)	A / R
17	34-00918-06	SCREW, HX WASHHD, 1/4-20 X .75	9
11	34-06051-06	RIVNUT, 1/4-20	9
18	68-07893-00	COVER, MICRO BOTTOM	1
19	68-13125-00	ANGLE, COVER MOUNTING	2

18.1.2 BOTTOM BUMPER KIT

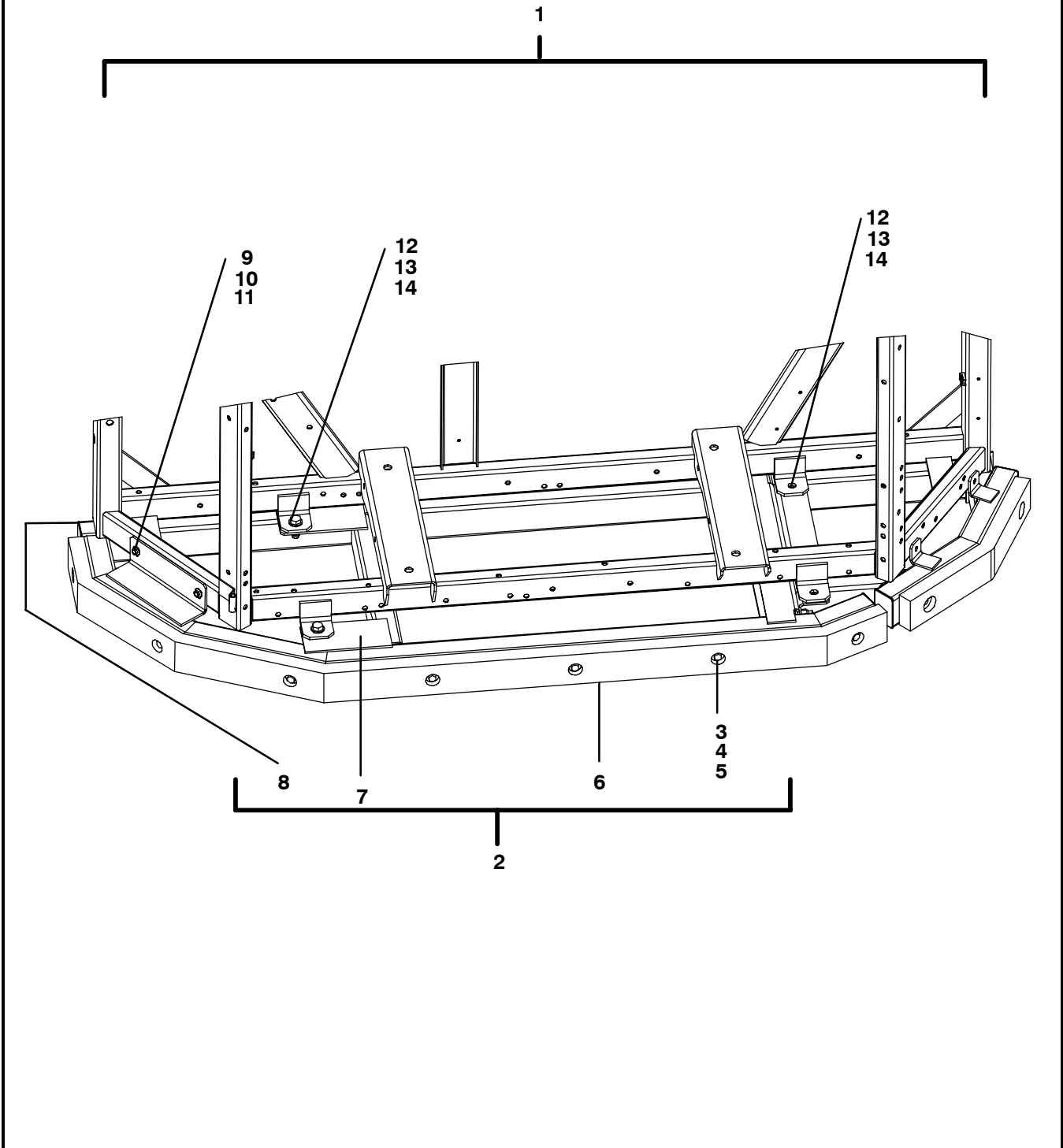

18.1.2 BOTTOM BUMPER KIT

Item	Part Number	Description	Qty
1	76-00571-00	BUMPER KIT, LOWER (REQUIRES 76-00559-00 MICRO BUMPER) - INCLUDES:	
2	79-02349-00	BUMPER ASSEMBLY, LOWER - INCLUDES	1
3	34-00304-28	SCREW, CAP HXHD, 3/8-16 X 3.50" L	7
4	34-00366-13	WASHER, PLAIN, 3/8"	14
5	34-00361-13	NUT, SELF LOCK, 3/8-16	7
6	58-01372-02	BUMPER, RUBBER, 1.25 X 3.00" L	1
7	86-03083-00	FRAME ASSEMBLY, BUMPER	1
8	58-04099-04	PLUG, RUBBER, 1.737 X 2.737" RECT.	2
9	34-00366-12	WASHER, PLAIN, 5/16"	2
10	34-00918-08	SCREW, HX WASHHD, 1/4-20 X 1.00" L	2
11	34-06051-06	RIVNUT, 1/4-20	2
12	34-00361-15	NUT, SELF LOCK, 1/2-13	6
13	34-00588-15	WASHER, PLAIN, 1/2"	12
14	34-00678-12	SCREW, CAP HXHD, 1/2-13 X 1.50" L	6

18.1.3 CONDENSER BUMPER KIT

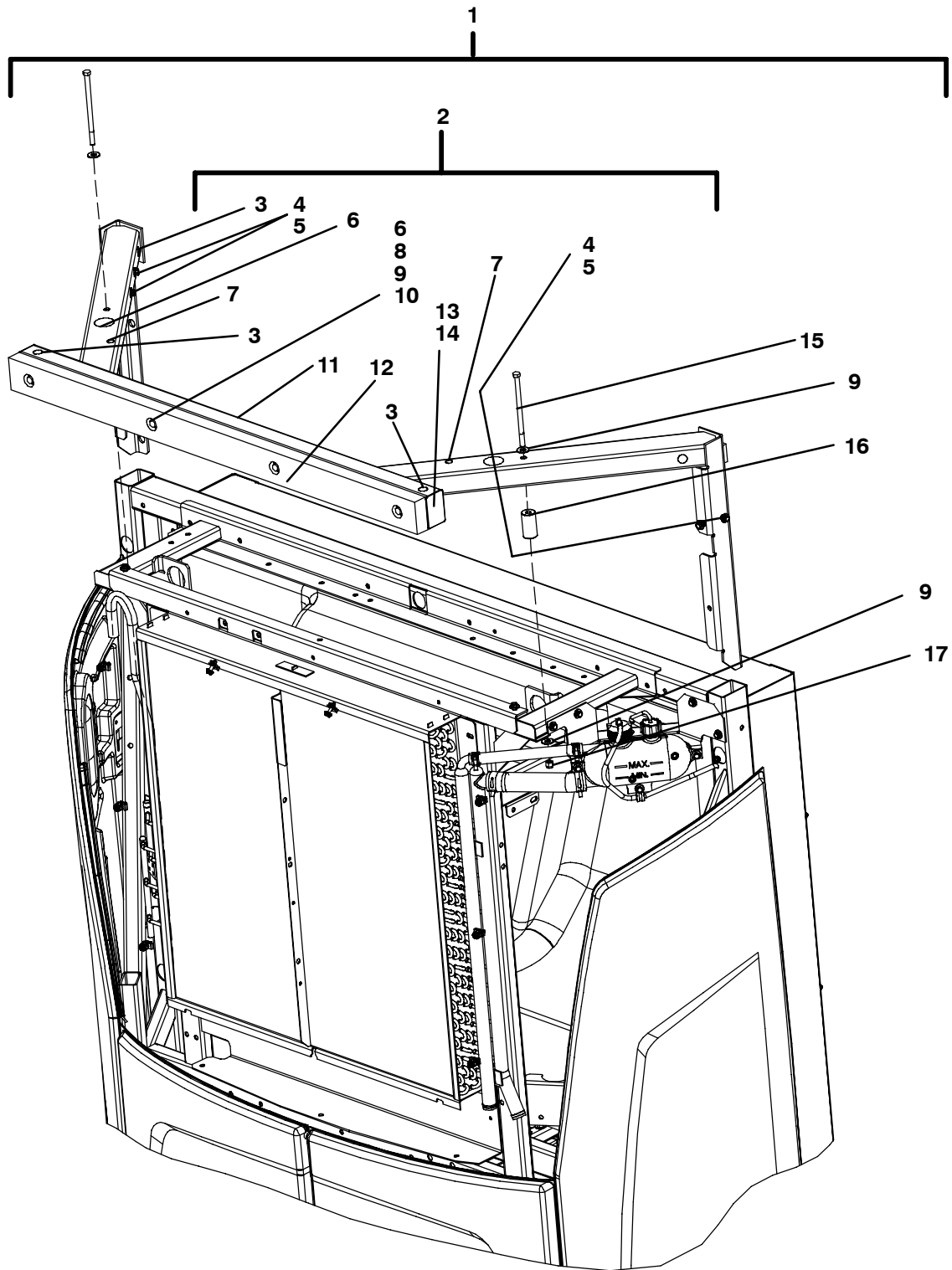

18.1.3 CONDENSER BUMPER KIT

Item	Part Number	Description	Qty
1	76-00792-00	BUMPER KIT, UPPER - INCLUDES:	1
2	79-01950-00	BUMPER ASSEMBLY, UPPER - INCLUDES:	1
3	58-00616-01	PLUG, HOLE, 0.69 DIAMETER X .12 PNL	8
4	34-01294-08	SCREW, CAPT WASH, 1/4-20 X 1.00" L	8
5	34-06051-06	RIVNUT, 1/4-20	8
6	58-00616-16	PLUG, HOLE, 1.50 DIAMETER X .12 PNL	4
7	58-00616-02	PLUG, HOLE, 0.50 DIAMETER X .12 PNL	8
8	34-00304-16	SCREW, CAP HXHD, 3/8-16 X 2.00" L	4
9	34-00366-13	WASHER, PLAIN, 3/8" ID	4
10	34-00368-13	WASHER, LOCK, 3/8" SPRING	4
11	86-04673-00	FRAME ASSEMBLY, UPPER BUMPER	1
12	58-01372-00	BUMPER, RUBBER, 1.25 X 3.00	1
13	58-04099-04	PLUG, RUBBER, 1.737 X 2.737 RECT.	2
14	86-02992-00	PLATE ASSEMBLY, NUT	1
15	34-00304-52	SCREW, CAP HXHD, 3/8-16 X 6.50" L	2
16	48-00419-00	SPACER, BUMPER FRAME	2
17	34-00361-13	NUT, SELF LOCK, 3/8-16	2
9	34-00366-13	WASHER, PLAIN, 3/8" ID	4

18.2 EVAPORATOR DRAINLINE EXTENSION AND TOP GRILL KITS

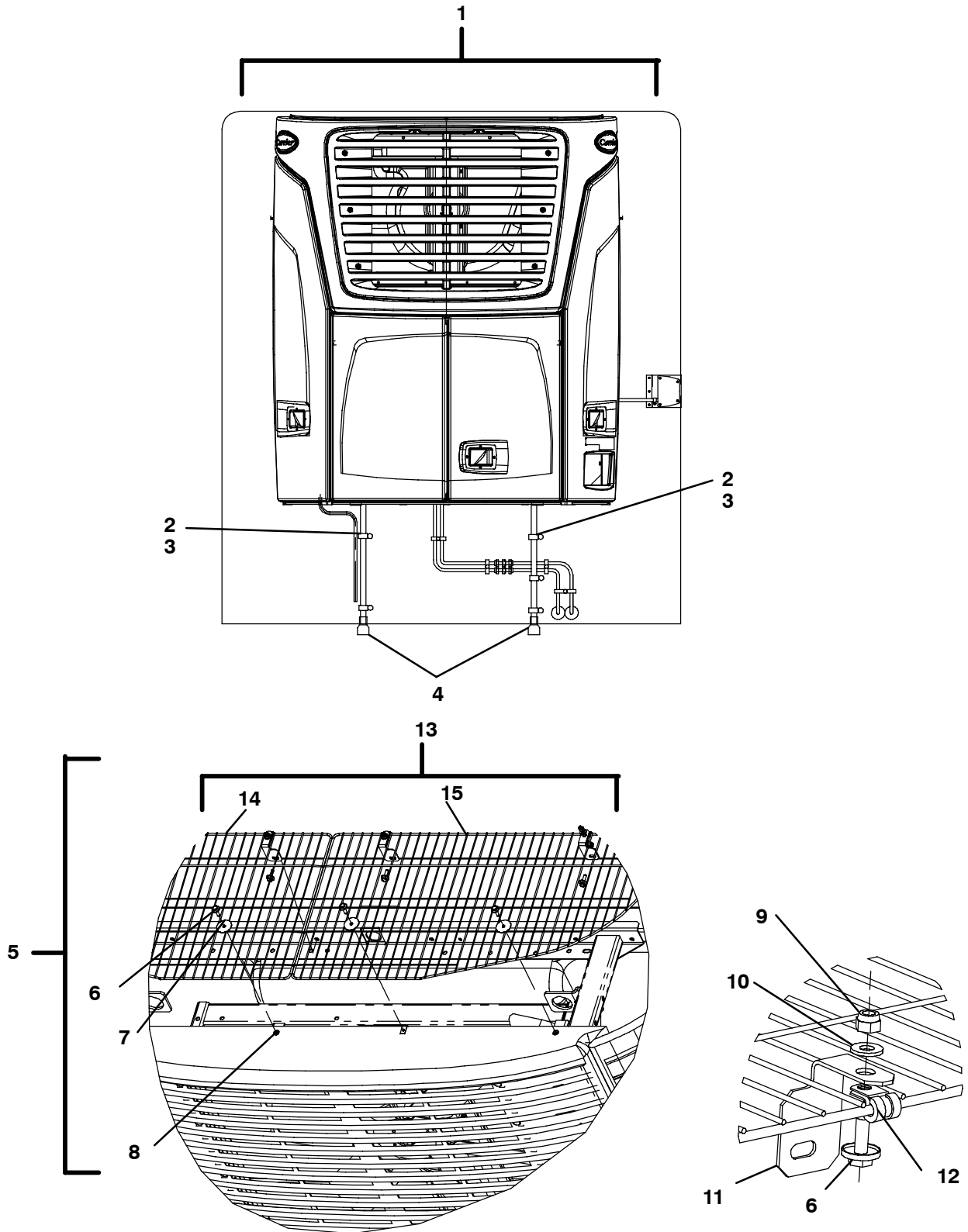

18.2 EVAPORATOR DRAINLINE EXTENSION KIT

Item	Part Number	Description	Qty
1	76-00554-00	INSTALL KIT, EVAPORATOR DRAIN EXTENSION - INCLUDES:	
2	58-00712-15	CLAMP, HOSE, .985-1.135 O.D. SNAP	2
3	58-00772-07	HOSE, DRAIN, .88" ID X 5 FT LONG	2
4	58-00253-00	KAZOO, DRAIN HOSE FITTING	2

18.3 TOP GRILL KIT

Item	Part Number	Description	Qty
5	76-00556-00	TOP GRILL KIT - INCLUDES:	
6	34-00918-08	SCREW, HX WASHHD, 1/4-20 X 1.00" L	8
7	34-00662-19	WASHER, PLAIN, .256" ID X 1.50" OD	4
8	34-06040-00	NUT CLIP, SPEED "U" 1/4-20	1
9	34-00361-11	NUT, SELF LOCK, 1/4-20	4
10	34-00588-11	WASHER, PLAIN, 1/4" ID	4
11	68-07868-00	BRACKET, TOP GRILL MOUNTING	4
12	34-00373-51	CLAMP, TUBE, .25" DIAMETER CUSHION	4
13	73-00334-20	GRILL ASSEMBLY, TOP, R.S. & C.S. SET - INCLUDES:	1
14	73-00334-00	GRILL, TOP, CURBSIDE	1
15	73-00334-01	GRILL, TOP, ROADSIDE	1

18.4 FUEL PUMP KIT

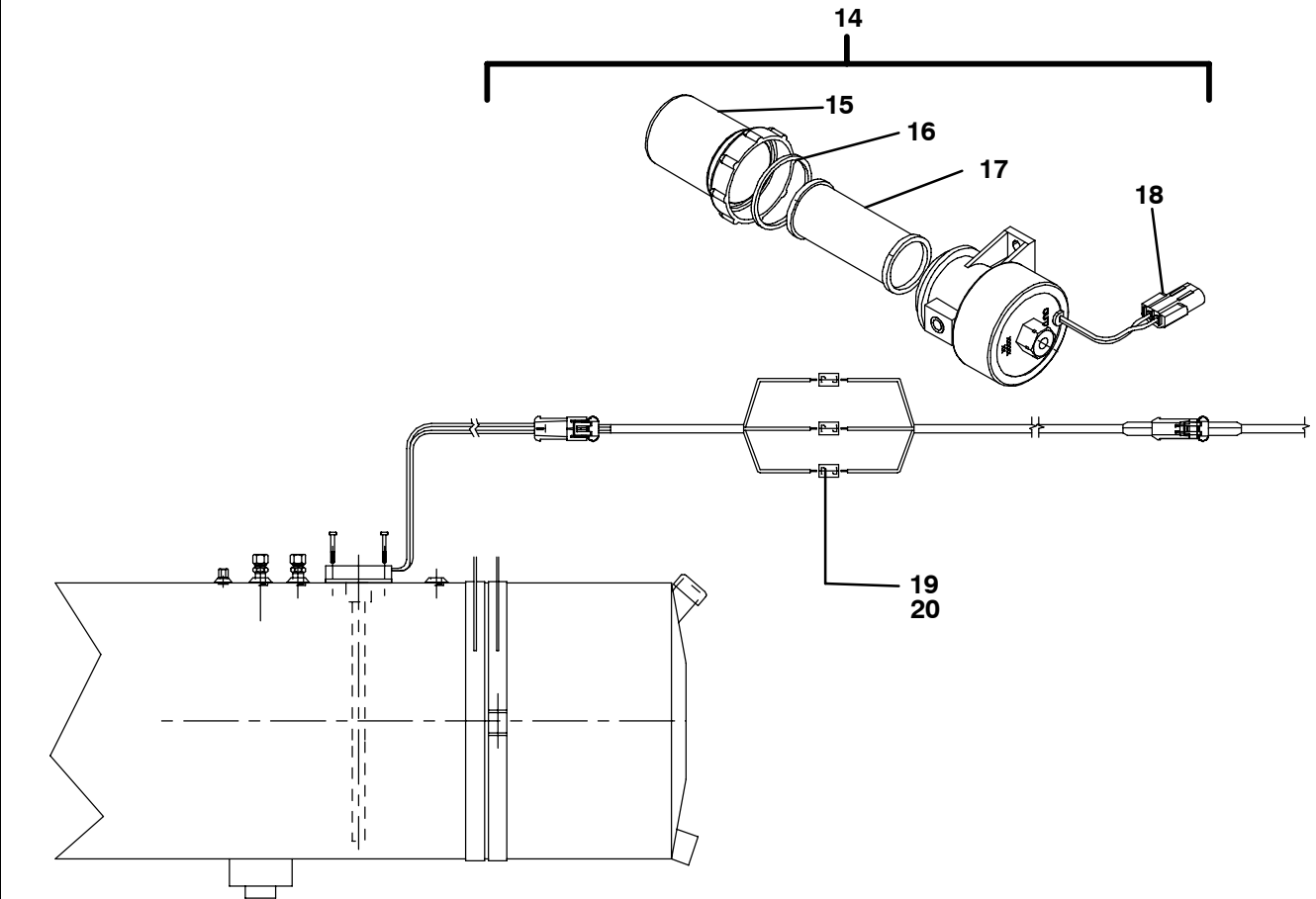
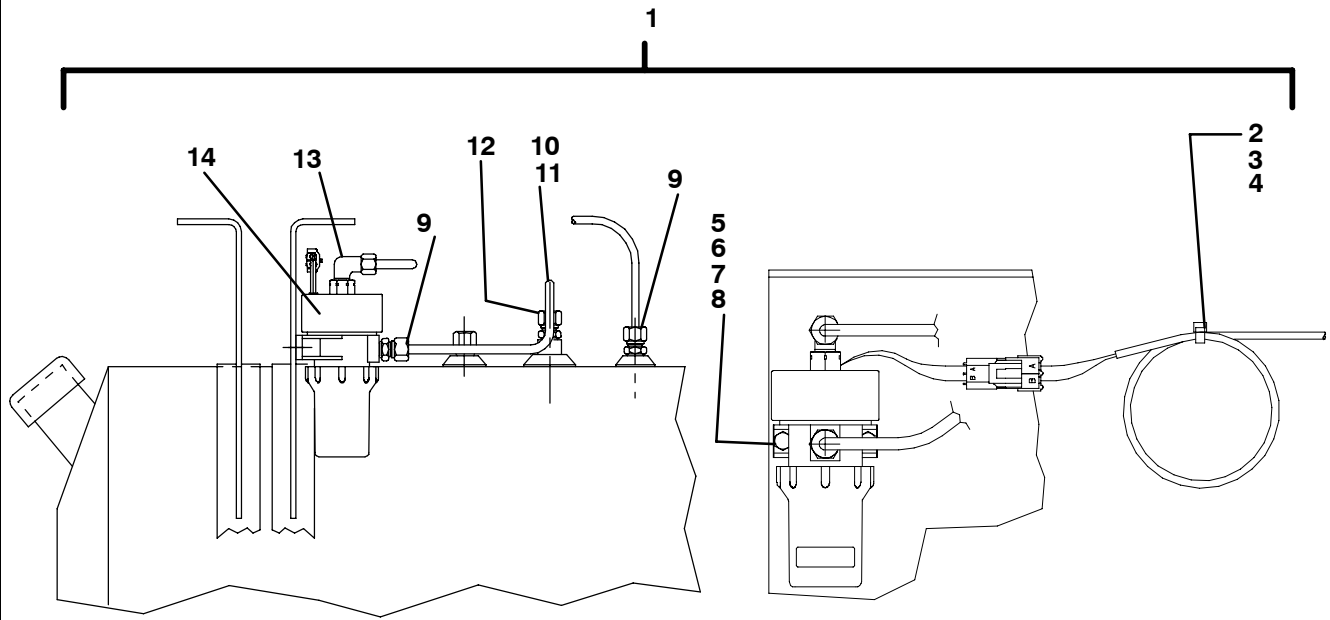

18.4 FUEL PUMP KIT

Item	Part Number	Description	Qty
1	76-00295-06	FUEL PUMP KIT - INCLUDES:	
2	22-60287-01	HARNESS, FUEL PUMP - INCLUDES:	1
3	22-01585-00SV	CONNECTOR, 2-WIRE (MATES WITH 22-02392-00SV)	1
4	58-00079-02	STA-STRAP, 0-1.75" DIAMETER CABLE	4
5	34-00300-08	SCREW, CAP HXHD, 1/4-20 X 1.00" L	2
6	34-00361-11	NUT, SELF LOCK, 1/4-20	2
7	34-00372-11	WASHER, LOCK, 1/4" EXT TOOTH	2
8	34-00588-11	WASHER, PLAIN, 1/4"	4
9	40-00343-07	CONNECTOR, MALE, 3/8 TUBE X 1/8 NPTE	1
10	44-00102-01	CLAMP, CUSHIONED, .50" DIAMETER	3
11	58-00508-99	TUBE, FUEL, .375 OD (SOLD IN 50 FT ROLL)	A / R
12	40-00450-01	CONNECTOR, MALE, 3/8 TUBE X 1/4 MPT	1
13	40-00342-02	ELBOW, MALE, 3/8 TUBE X 1/8 NPTE	1
14	30-01108-01SV	PUMP, FUEL, 12VDC - INCLUDES:	1
15	30-01108-23	BOWL, FUEL PUMP	1
16	30-01108-22	GASKET, BOWL	1
17	30-01108-20	FILTER, FUEL PUMP (80-MICRON)	1
18	22-02392-00SV	CONNECTOR, 2-WIRE (MATES WITH 22-01585-00SV)	1
19	22-00066-02	CONNECTOR, BUTT SPLICE, 14-16 GAUGE	2
20	66U1-3803	TUBE, HEAT SHRINK, 1/4 X 2.00" LG.	2

18.5 LIGHTBAR KIT - STANDARD AND LED

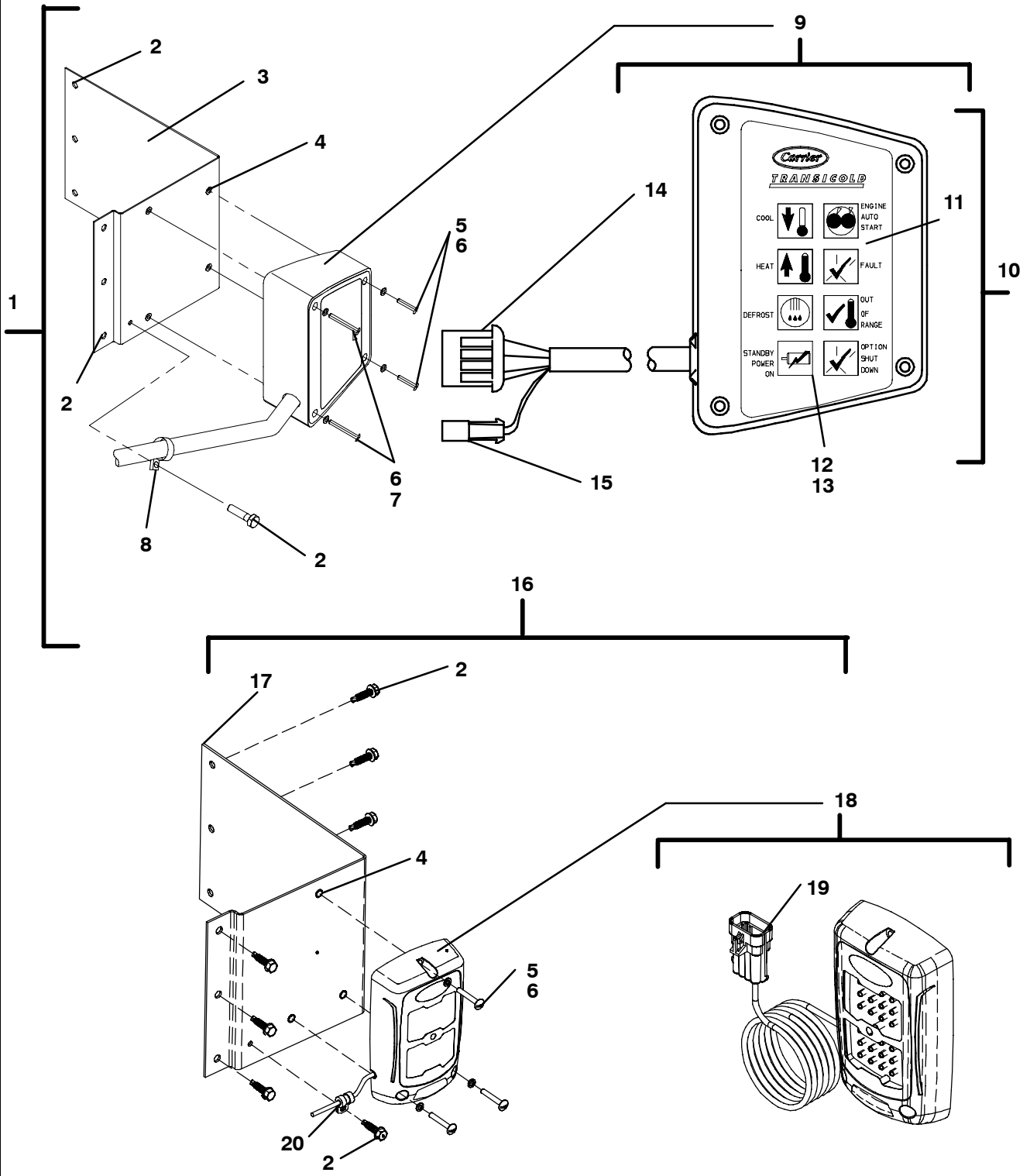

18.5.1 LIGHTBAR KIT - STANDARD AND LED

Item	Part Number	Description	Qty
1	76-00542-00	LIGHTBAR KIT, STANDARD - INCLUDES:	
2	34-01276-08	SCREW, HX WASHHD, 1/4 X 1.00" L, SELF-TAPPING	11
3	68-11009-00	BRACKET, LIGHTBAR MOUNTING	1
4	34-06051-34	RIVNUT, # 10-32	4
5	34-00670-20	SCREW, ROUND HD, # 10-32 X 1.25" L	2
6	34-00663-09	WASHER, LOCK, # 10	4
7	34-00670-30	SCREW, ROUND HD, # 10-32 X 2.00" L	2
8	34-00373-06	CLAMP, TUBE, .56 DIAMETER CUSHION	5
9	22-01465-71	LIGHT BAR ASSEMBLY, REMOTE - INCLUDES:	1
10	22-01465-51SV	HOUSING, LIGHTBAR - INCLUDES:	1
11	22-01465-53	DECAL, LIGHTBAR FACE	1
12	22-01467-00	LAMP, WEDGE BASE	8
13	22-01468-20	HOLDER, LAMP	8
14	22-50078-04SV	CONNECTOR, 8-WIRE (MATES WITH 22-50078-03SV)	1
15	22-50078-01SV	CONNECTOR, 2-WIRE (MATES WITH 22-50078-02SV)	1

18.5.2 LIGHTBAR KIT - LED

Item	Part Number	Description	Qty
16	76-02000-00	LIGHTBAR KIT, L.E.D. - INCLUDES:	
17	68-08042-00	BRACKET, LIGHTBAR MOUNTING	1
18	22-02842-00	LIGHT BAR ASSEMBLY, LED - INCLUDES:	1
19	22-50078-04SV	CONNECTOR, 8-WIRE (MATES WITH 22-50078-03SV)	1
4	34-06051-34	RIVNUT, # 10-32	3
6	34-00663-09	WASHER, LOCK, # 10	4
20	34-00373-50	CLAMP, TUBE, .19 DIAMETER CUSHION	5
5	34-00670-20	SCREW, ROUND HD, # 10-32 X 1.25" L	3
2	34-01276-08	SCREW, HX WASHHD, 1/4 X 1.00" L, SELF-TAPPING	11

18.6 REMOTE TEMPERATURE PROBE KIT - 75 & 100 FT

TEMP PROBE

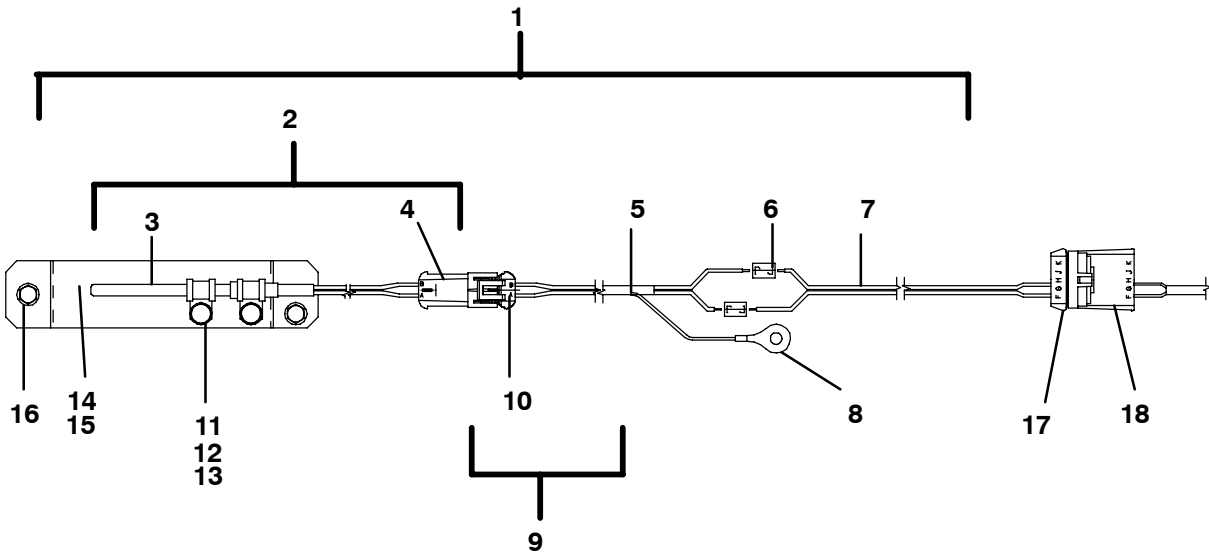

PULP PROBE

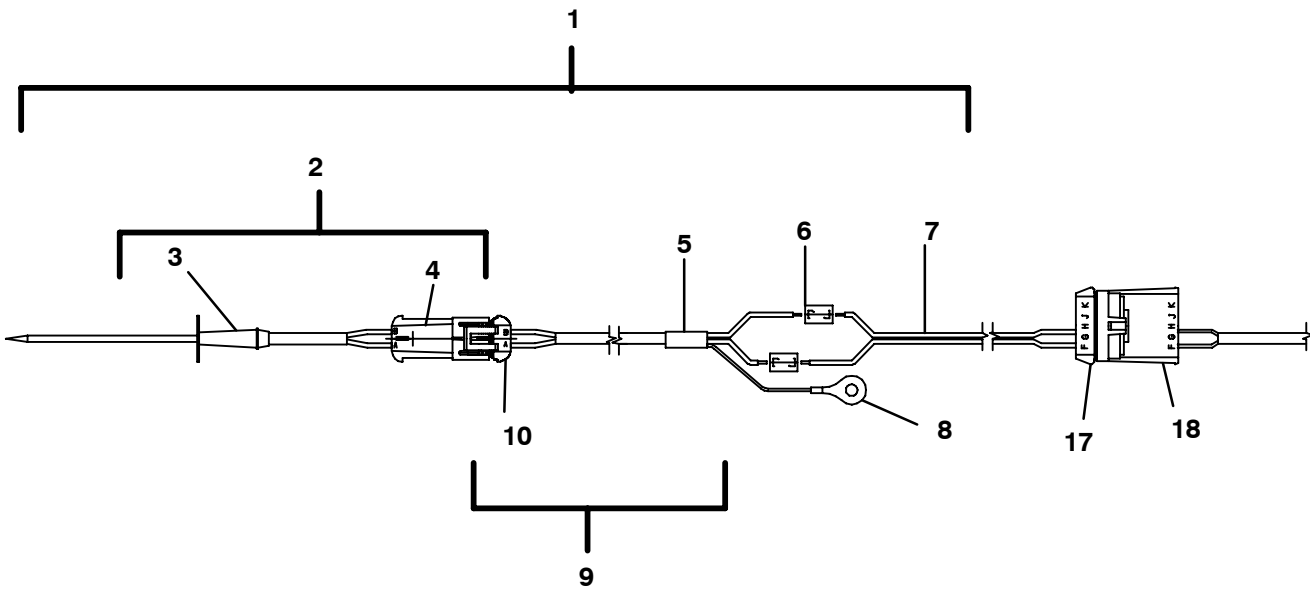

18.6 REMOTE TEMPERATURE PROBE KIT - 75 & 100 FT.

Item	Part Number	Description	Qty
1	76-00725-00	REMOTE TEMP PROBE KIT, 75 FT - INCLUDES:	
	76-00725-03	REMOTE TEMP PROBE KIT, 100 FT. - INCLUDES:	
	76-00725-02	REMOTE PULP PROBE KIT, 75 FT. - INCLUDES:	
2	22-01940-00	HARNESS ASSEMBLY, REMOTE SENSOR - INCLUDES:	
	22-02809-00	HARNESS ASSEMBLY, PULP PROBE - INCLUDES:	1
3	12-00523-00	SENSOR, THERMISTOR (TEMPERATURE PROBE ONLY)	1
	12-00342-03	SENSOR, THERMISTOR (PULP PROBE ONLY)	1
4	22-50078-01SV	CONNECTOR, 2-WIRE (MATES WITH 22-50078-02SV)	1
5	22-02811-00	TERMINAL, SOLDER SLEEVE	1
6	22-01451-00	BUTT SPLICE, RED INSULATION (16-22 GAUGE)	2
	22-01451-01	BUTT SPLICE, BLUE INSULATION (14-16 GAUGE)	2
7	22-01926-00	WIRE ASSEMBLY, REMOTE SENSOR	2
8	22-02812-00	WIRE ASSEMBLY, GROUND, 12" WITH RING	1
9	22-01857-00	HARNESS, REMOTE SENSOR, 75 FT. - INCLUDES:	1
	22-01857-01	HARNESS, REMOTE SENSOR, 100 FT. - INCLUDES:	1
10	22-50078-02SV	CONNECTOR, 2-WIRE (MATES WITH 22-50078-01SV)	1
11	34-00373-51	CLAMP, TUBE, .25 DIAMETER CUSHION	22 / 20
12	34-00655-06	SCREW, CAP HXHD, 1/4-20 X .75" L (TEMP PROBE ONLY)	2
13	34-00663-11	WASHER, LOCK, 1/4" (TEMPERATURE PROBE ONLY)	2
14	42-01170-01	GASKET, .38 THK (TEMPERATURE PROBE ONLY)	1
15	67-00051-00	BRACKET, SENSOR MOUNTING (TEMPERATURE PROBE ONLY)	1
16	34-01276-08	SCREW, HX WASHHD, 1/4 X 1.00" L, SELF-TAPPING (TEMPERATURE PROBE ONLY)	22 / 20
17	22-50078-44SK	CONNECTOR, 10 WIRE (MATES W/22-50078-45SV) (ON ENGINE HARNESS)	1
18	22-50078-45SK	CONNECTOR, 10 WIRE (MATES W/22-50078-44SV) (ON ENGINE HARNESS)	1

18.7 REMOTE PANEL KIT - FLUSH MOUNT

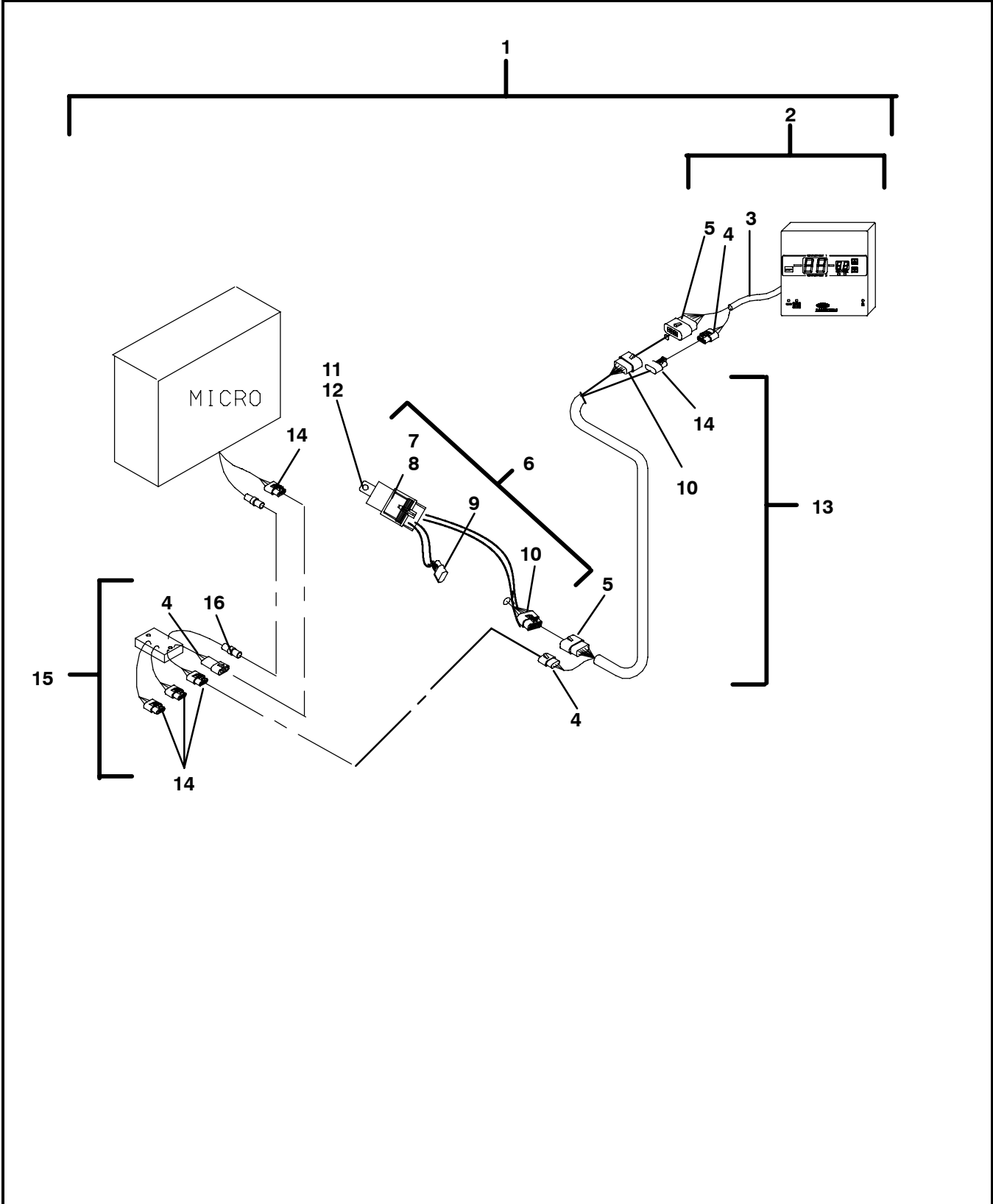

18.7 REMOTE PANEL KIT - FLUSH MOUNT

Item	Part Number	Description	Qty
1	76-60876-07	REMOTE PANEL KIT, FLUSH MOUNT - INCLUDES:	1
2	91-60112-09	MODULE, CONTROL PANEL, FLUSH MOUNT - INCLUDES:	1
3	22-60193-00	CABLE, 12-CONDUCTOR, 3 M (9.8 FT.) LONG	1
4	22-50078-08SV	CONNECTOR, 3-WIRE (MATES WITH 22-50078-05SV)	1
5	22-50078-45SV	CONNECTOR, 10-WIRE (MATES WITH 22-50078-44SK)	1
6	22-02810-00	HARNESS, REMOTE PANEL - INCLUDES:	1
7	10-00286-15	RELAY, 12 VDC, RCR	1
8	22-50098-92	SOCKET, RELAY, RCR	1
9	22-50078-01SV	CONNECTOR, 2-WIRE (MATES WITH 22-50078-02SV)	1
10	22-50078-44SK	CONNECTOR, 10-WIRE (MATES WITH 22-50078-45SV)	1
11	34-00588-11	WASHER, PLAIN, 1/4" ID	1
12	34-00361-11	NUT, SELF LOCK, 1/4-20	1
13	76-60798-05	EXTENSION HARNESS, 5 METERS (16.4 FT.) - INCLUDES:	1
	76-60798-10	EXTENSION HARNESS, 10 METERS (32.8 FT.) - INCLUDES:	1
	76-60798-15	EXTENSION HARNESS, 15 METERS (49.2 FT.) - INCLUDES:	1
	76-60798-20	EXTENSION HARNESS, 20 METERS (65.6 FT.) - INCLUDES:	1
10	22-50078-44SK	CONNECTOR, 10-WIRE (MATES WITH 22-50078-45SV)	1
14	22-50078-05SV	CONNECTOR, 3-WIRE (MATES WITH 22-50078-08SV)	1
4	22-50078-08SV	CONNECTOR, 3-WIRE (MATES WITH 22-50078-05SV)	1
5	22-50078-45SV	CONNECTOR, 10-WIRE (MATES WITH 22-50078-44SK)	1
15	12-60040-00	SERIAL PORT INTERFACE / SPLITTER, RS232 - INCLUDES:	1
4	22-50078-08SV	CONNECTOR, 3-WIRE (MATES WITH 22-50078-05SV)	1
14	22-50078-05SV	CONNECTOR, 3-WIRE (MATES WITH 22-50078-08SV)	3
16	22-50078-64SV	CONNECTOR, 1-WIRE (MATES W/22-50078-63SV)	1

18.8 LOW-FUEL SHUTDOWN KIT

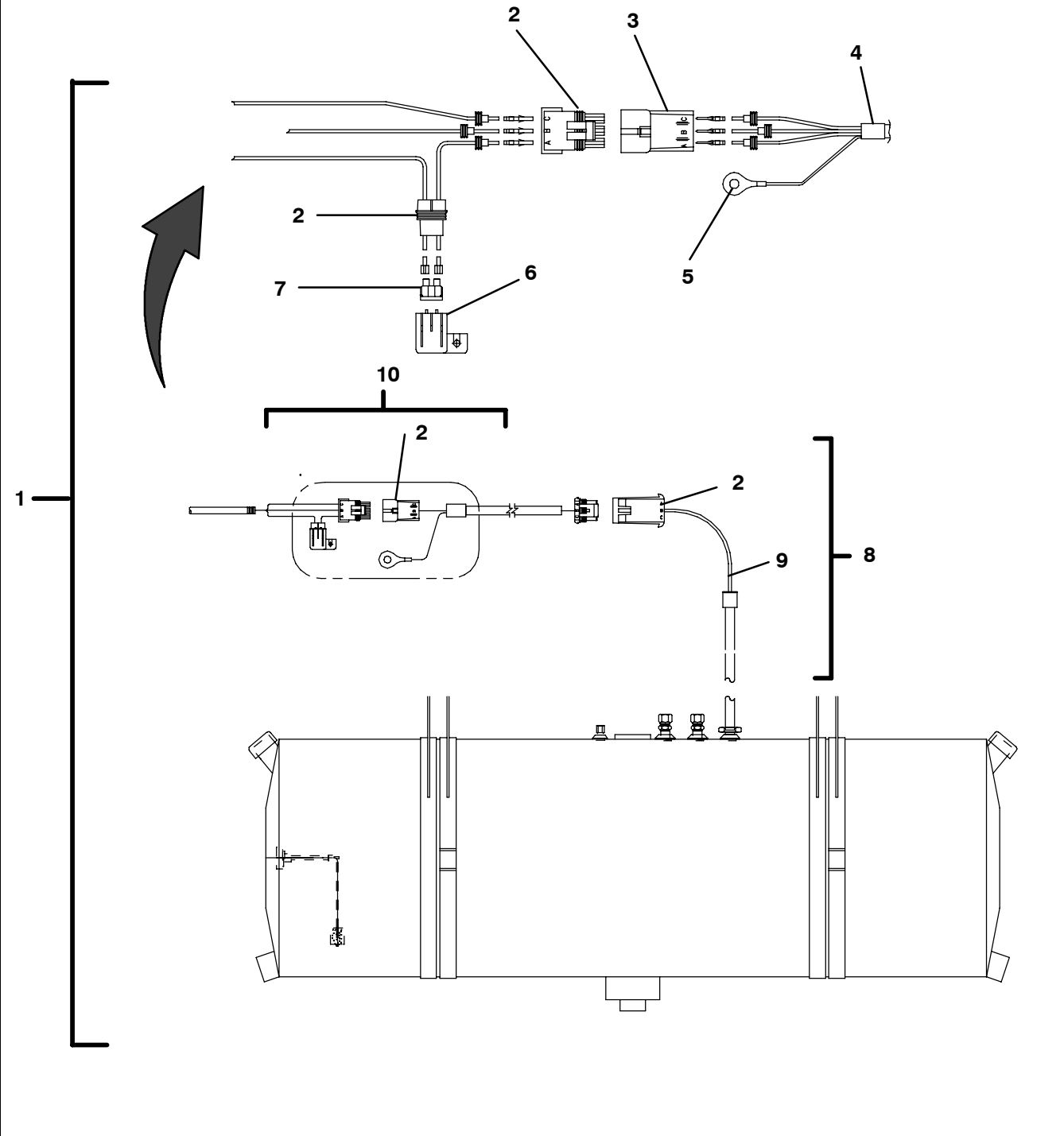

18.8 LOW-FUEL SHUTDOWN KIT

Item	Part Number	Description	Qty
1	76-00578-08	SHUTDOWN KIT, LOW FUEL - INCLUDES:	
2	22-01586-00	CONNECTOR, 3-WIRE (MATES WITH 22-50098-60)	1
3	22-50098-60	CONNECTOR, 3-WIRE (MATES WITH 22-01586-00)	1
4	22-02811-00	TERMINAL, SOLDER SLEEVE	1
5	22-02812-00	WIRE ASSEMBLY, GROUND, 12" WIRING	1
6	22-50078-22SV	FUSE HOLDER AND COVER	1
7	22-02336-03	FUSE, 3-AMP	1
8	12-00548-09SV	SENSOR, LOW FUEL (IN TANK) - INCLUDES:	1
9	22-04036-00	HARNESS, CSP PATCH CABLE	1
2	22-01586-00	CONNECTOR, 3-WIRE (MATES WITH 22-50098-60)	1
10	22-02836-00	WIRE HARNESS, FUEL LEVEL SENSOR - INCLUDES:	1
2	22-01586-00	CONNECTOR, 3-WIRE (MATES WITH 22-50078-25)	1

18.9 DOOR SWITCH SHUTDOWN & REMOTE SWITCH KITS

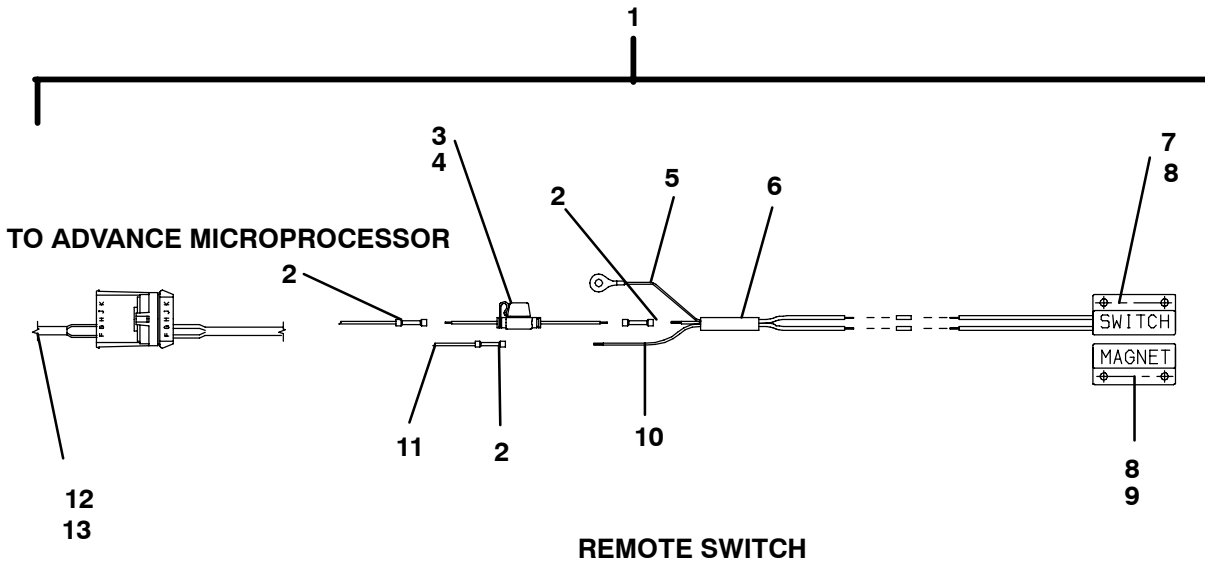
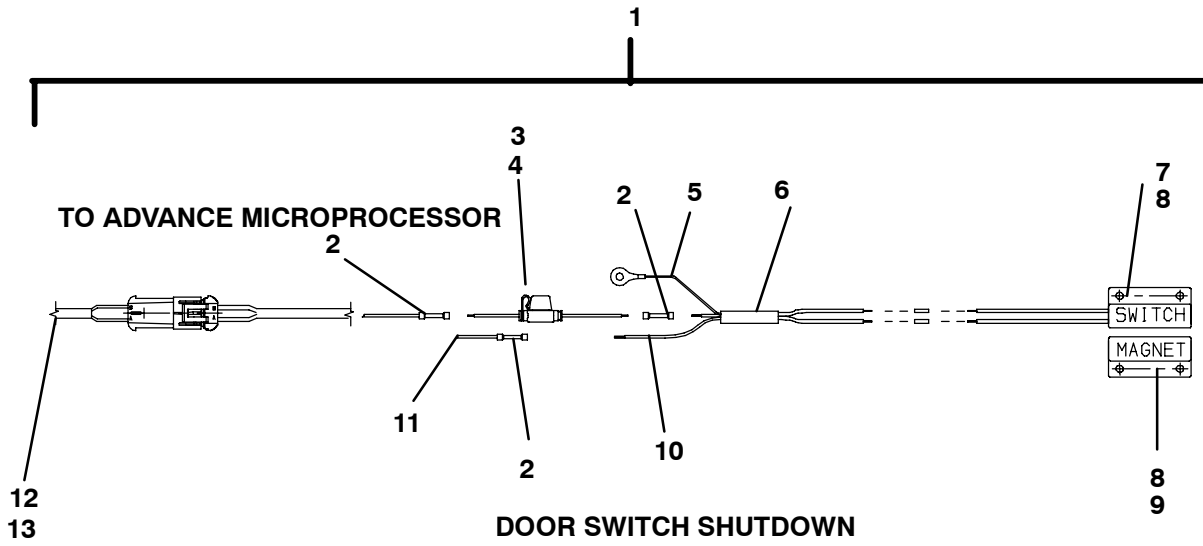

18.9 DOOR SWITCH SHUTDOWN & REMOTE SWITCH KITS

Item	Part Number	Description	Qty
1	76-00725-01	SHUTDOWN KIT, DOOR SWITCH - INCLUDES:	
2	22-01451-00	BUTT SPLICE, RED, INSULATION (16-22 GAUGE)	5
	22-01451-01	BUTT SPLICE, BLUE, INSULATION (14-16 GAUGE)	5
3	22-02336-19	FUSE, MINI, 3-AMP.	1
4	22-02338-03	FUSE HOLDER, MINI-FUSE	1
5	22-02812-00	WIRE ASSEMBLY, GROUND, 12" WITH RING	1
6	22-02811-00	TERMINAL, SOLDER SLEEVE	1
7	12-00419-04	SWITCH, MAGNETIC, DOOR	1
8	34-06109-08	SCREW, TF HXHD, # 10-16 X 1.00" L	4
9	12-00419-03	MAGNET, DOOR SWITCH	1
10	22-01443-00	CABLE, 2-CONDUCTOR (SOLD IN 150 FT. ROLL)	75
11	22-01926-00	WIRE ASSEMBLY, DOOR SWITCH (2-CONNECTOR)	2
	22-01926-01	WIRE ASSEMBLY, DOOR SWITCH (10-CONNECTOR)	2
12	34-00373-51	CLAMP, TUBE, .25" DIAMETER CUSHION	22
13	34-01276-08	SCREW, HX WASHHD, 1/4 X 1.00" L SELF-TAPPING	22

PART NUMBER INDEX

PART NO.	PAGE NO.	PART NO.	PAGE NO.	PART NO.	PAGE NO
04-00058-00	40	12-60040-00	3, 95	22-01585-00SV	42, 67, 89
04-00122-30	39	14-00150-51	21, 23, 24	22-01585-04	67
04-00122-30SV	29	14-00176-02	4, 33	22-01586-00	67, 97
07-00303-02	39	14-00199-00	3, 21	22-01622-00	65
07-00396-01	39	14-00209-00	2, 21	22-01633-00	73
07-00423-00	53	14-00209-20	2, 21	22-01633-01	73
07-00432-00	39	14-00232-25	4, 33	22-01633-10	73
08-00197-01	4, 33	14-00232-28	4, 33	22-01633-11	73
08-00225-02	3, 29	14-00263-03	3, 25	22-01660-03	61, 67
08-00305-00	3, 19	14-00263-20	25	22-01660-05	61
08-00306-00	3, 19	14-00263-22	25	22-01661-00	2, 69
10-00286-15	95	14-00308-00	3, 21, 25	22-01662-01	69
10-00328-00	65	14-00309-03	3, 22	22-01857-00	2, 93
10-00375-01SV	3, 63	14-00310-01	3, 21, 24	22-01857-01	2, 93
10-00591-00	4, 34	14-00322-00	3, 22	22-01900-00	63
10-01129-15SV	3, 63	14-00324-01	3, 21	22-01926-00	93, 99
10-01129-16SV	3, 63	14-00331-00	3, 22	22-01926-01	99
12-00284-00	3, 42	14-00348-04	3, 21, 23	22-01940-00	2, 93
12-00303-00	3, 19	14-00348-05	3, 21, 24	22-01943-00	2, 61
12-00309-04	3, 43	14-00350-03	3, 21, 23, 24	22-01951-00	2, 33
12-00342-03	3, 93			22-01951-01	2, 33
12-00352-03SV	3, 21	14-01114-20	3, 21	22-02336-01	2, 65
12-00352-04	3, 43	14-01114-51	21	22-02336-03	2, 67, 97
12-00419-03	3, 99	17-40013-00	21	22-02336-04	2, 65
12-00419-04	3, 99	17-44138-00	22	22-02336-06	69
12-00439-02RP	71	17-44141-00	25	22-02336-09	2, 69
12-00450-00SV	71	18-00091-105	1, 42	22-02336-10	2
12-00495-02SV	3, 61	22-00060-03	2, 65	22-02336-19	2, 99
12-00495-03	33	22-00060-35	2, 69	22-02336-21	2, 69
12-00504-50/0404	65	22-00066-02	89	22-02338-03	2, 99
12-00523-00	3, 93	22-01100-00	19	22-02338-05	2, 69
12-00523-01	3, 33	22-01443-00	99	22-02392-00SV	43, 67, 89
12-00548-09S	97	22-01451-00	93, 99	22-02392-03SV	25
12-00589-02	41	22-01451-01	93, 99	22-02448-00SV	67
12-00592-00	3, 41	22-01465-51SV	91	22-02579-00	3, 21, 23, 24
12-00601-00	3, 57	22-01465-53	91		
12-01145-03	3, 42, 47	22-01465-71	91	22-02804-00	4, 42
12-01147-01	3	22-01467-00	91	22-02809-00	2, 93
12-55438-11/0404	65	22-01468-20	91	22-02810-00	2, 95

PART NUMBER INDEX

PART NO.	PAGE NO.	PART NO.	PAGE NO.	PART NO.	PAGE NO
22-02811-00	93, 97, 99	22-50098-18	67	30-00463-00P12	1, 2, 41
22-02812-00	93, 97, 99	22-50098-24	69	30-00471-01	58
22-02824-01	2	22-50098-50	67	30-00471-20	2, 58
22-02836-00	97	22-50098-56	34	30-00471-30	58
22-02839-00	2	22-50098-57	67	30-00471-31	58
22-02842-00	91	22-50098-58	33	30-01079-01	2, 51
22-04025-00	2, 65, 69	22-50098-60	21, 97	30-01090-04	2, 51
22-04025-01	2, 65, 69	22-50098-61	67	30-01090-11	2, 51
22-04036-00	21, 97	22-50098-62	67	30-01097-24	54
22-04042-00	2, 65	22-50098-92	95	30-01097-27	54
22-04048-01	2, 61, 67	22-50099-06	67	30-01097-28	54
22-04060-00	61	22-50244-00	65	30-01097-38	54
22-04073-00	57	22-50251-01	3	30-01098-27	51
22-50078-01SV	21, 39, 41, 51, 54, 61, 67, 91, 93, 95	22-60193-00	95	30-01098-28	51
22-50078-02SV	21, 23, 24, 41, 42, 47, 57, 67, 93	22-60287-01	2, 89	30-01100-00	53
22-50078-03SV	67	25-39316-00	1, 41	30-01104-04	51
22-50078-04SV	91	26-00120-00	1, 41	30-01104-05	51
22-50078-05SV	67, 95	26-00120-01	1, 41	30-01104-50	51
22-50078-07SV	49	30-00006-00	61	30-01104-51	51
22-50078-08SV	95	30-00171-13	49	30-01105-00	51, 53
22-50078-18	69	30-00171-29	49	30-01106-00	53, 54
22-50078-20SV	67	30-00171-31	49	30-01106-01	53, 54
22-50078-21SV	67	30-00175-01	1, 59	30-01106-20	54
22-50078-22SV	2, 67, 97	30-00328-01	3, 58	30-01106-21	54
22-50078-30	67	30-00409-11	47, 49	30-01106-22	54
22-50078-44SK	93, 95	30-00409-30	49	30-01106-23	54
22-50078-45SK	93	30-00409-32	49	30-01106-25	2, 54
22-50078-45SV	67, 95	30-00409-35	49	30-01106-26	54
22-50078-61SV	2, 69	30-00409-44	49	30-01106-27	54
22-50078-64SV	95	30-00409-51	49	30-01106-28	54
22-50078-82	67	30-00409-52	49	30-01108-01SV	89
22-50078-86SV	69	30-00409-53	49	30-01108-20	2, 89
22-50078-87SV	67	30-00409-54	49	30-01108-22	89
22-50078-92	67	30-00409-55	49	30-01108-23	89
22-50098-10	69	30-00409-56	49	34-00172-05	1, 77
22-50098-16	67	30-00409-57	49	34-00300-06	9
22-50098-17	67	30-00409-65	47, 49	34-00300-08	34, 89
		30-00452-01	59	34-00300-18	19
		30-00453-01	59	34-00300-24	19

PART NUMBER INDEX

PART NO.	PAGE NO.	PART NO.	PAGE NO.	PART NO.	PAGE NO
34-00302-06	37	34-00373-01	1, 55	34-00665-10	29
34-00302-10	7, 43, 53	34-00373-03	1, 53, 55	34-00666-11	61, 63
34-00302-14	53	34-00373-05	1, 19, 51, 57	34-00666-12	29
34-00302-18	21	34-00373-06	1, 91	34-00667-05	61
34-00304-08	40, 42	34-00373-07	1, 19, 31	34-00667-111	31
34-00304-10	53	34-00373-15	51	34-00667-112	27
34-00304-12	51	34-00373-50	1, 91	34-00670-20	91
34-00304-14	39, 42	34-00373-51	1, 29, 31, 87, 93, 99	34-00670-30	91
34-00304-16	85	34-00373-69	1	34-00675-14	37
34-00304-28	83	34-00373-70	57	34-00676-40	41
34-00304-52	85	34-00558-09	31	34-00678-12	81, 83
34-00308-20	21	34-00559-08	42	34-00678-16	47
34-00309-14	43	34-00588-11	87, 89, 95	34-00699-03	34, 35
34-00361-07	65	34-00588-12	9, 47	34-00775-06	39
34-00361-08	63	34-00588-15	47, 77, 81, 83	34-00775-10	29, 39
34-00361-11	87, 89, 95	34-00615-08	47	34-00775-12	40
34-00361-12	7, 9, 53	34-00615-10	47	34-00795-09	65
34-00361-13	19, 83, 85	34-00615-16	39	34-00827-10	63
34-00361-15	77, 81, 83	34-00615-18	7	34-00829-09	71
34-00363-11	34	34-00615-36	7	34-00829-11	11, 13
34-00366-08	63	34-00616-00	42	34-00829-13	27
34-00366-11	34	34-00636-11	34	34-00829-15	61
34-00366-12	7, 43, 53, 59, 83	34-00655-04	13	34-00873-50	47
34-00366-13	40, 61, 73, 83, 85	34-00655-06	11, 13, 29, 31, 93	34-00876-16	58
34-00366-15	81	34-00655-08	15, 17, 29, 31	34-00876-20	43, 51
34-00366-17	41	34-00662-05	61	34-00890-07	41
34-00368-11	9, 19, 29, 39, 40, 61	34-00662-11	15, 29, 31	34-00890-10	41
34-00368-12	39, 43, 47	34-00662-12	27, 29, 73	34-00917-16	65
34-00368-13	39, 40, 42, 47, 85	34-00662-19	87	34-00918-04	19
34-00368-15	37, 47	34-00662-20	17, 29, 31, 65	34-00918-06	34, 81
34-00372-11	89	34-00663-09	91	34-00918-08	81, 83, 87
34-00372-39	65	34-00663-11	11, 13, 15, 17, 29, 31, 34, 93	34-00919-08	7, 40, 73, 81
34-00372-41	61, 63	34-00663-12	29, 73	34-00927-00	41
34-00372-43	61			34-00928-13	31
34-00372-44	61			34-00932-13	59
34-00372-45	61			34-00944-08	43, 51, 58
				34-00944-10	47, 51, 53
				34-00945-08	42, 43, 51, 58

PART NUMBER INDEX

PART NO.	PAGE NO.	PART NO.	PAGE NO.	PART NO.	PAGE NO
34-00945-10	47, 51	34-06051-37	17, 27, 31	40-01153-00	51, 53
34-00946-08	47	34-06053-04	63	40-01156-00	51, 53
34-00960-16	26	34-06109-08	99	40-60007-01	5
34-00962-25	61	34-06126-08	61	40-60007-02	5
34-00964-00	42	34-06129-06	71	40-60007-03	5
34-00996-08	19	34-06134-07	61	40-60007-04	5
34-01146-05	65	34-06196-10	71	40-60007-11	5
34-01151-05	65	34-06196-11	71	40-60008-01	5
34-01184-06	11, 13	34-06265-08	63	40-60008-02	5
34-01226-00	63	34-06310-00	15	40-60008-03	5
34-01236-12	27	34-06311-08	15	40-60008-04	5
34-01241-20	42	34-06312-08	15	40-60008-07	5
34-01247-80	73	34-06315-00	37	40-60009-01	5
34-01249-21	53	34-06316-00	37	40-60009-02	5
34-01276-08	55, 77, 91, 93, 99	34-60000-25	65	40-60009-03	5
34-01279-12	47	38-00528-00	39	40-60009-04	5
34-01284-00	11, 13	38-00556-20SV	29	40-60009-06	5
34-01294-06	9, 15, 19, 61, 77	40-00060-01	53	40-60029-02	21, 24
34-01294-08	7, 19, 35, 51, 53, 57, 58, 73, 85	40-00060-02	53	42-00032-00	31
34-06003-12	61	40-00071-11	25	42-00183-00	81
34-06025-06	77	40-00086-04	25	42-00183-22	73
34-06026-00	42	40-00102-04	25	42-00237-52	19
34-06038-00	21	40-00121-01	43	42-00237-54	19
34-06039-00	61, 63	40-00130-07	33	42-00243-00	5
34-06040-00	87	40-00169-08	22	42-00243-03	5
34-06051-04	65	40-00243-00	43	42-00243-04	5
34-06051-06	7, 9, 19, 34, 53, 57, 61, 65, 77, 81, 83, 85	40-00342-02	89	42-00243-09	5
34-06051-07	51	40-00342-04	53	42-00243-10	5
34-06051-10	7, 81	40-00343-07	89	42-00243-14	63
34-06051-11	17, 43, 73	40-00349-00	55	42-00258-00	29
34-06051-14	51	40-00349-01	55	42-00258-09	26
34-06051-34	91	40-00420-00	39, 53	42-00258-10	26
34-06051-36	15, 17, 26, 29, 31	40-00420-01	53	42-00264-04	79
		40-00420-02	40	42-00264-11	13
		40-00450-00	55	42-00264-12	13
		40-00450-01	55, 89	42-00264-13	77
		40-00501-50	24	42-00264-14	77
		40-00593-00	43	42-00264-16	15
		40-01124-00	25	42-00372-00	29

PART NUMBER INDEX

PART NO.	PAGE NO.	PART NO.	PAGE NO.	PART NO.	PAGE NO
42-00386-00	26	44-00435-00	65	50-00178-26	1, 35
42-00392-00	17	44-00436-00	65	50-00214-47	40
42-00396-00	71	44-00439-00	9	50-00224-00	40
42-00405-00	71	44-00440-00	9	50-00224-04	40
42-00406-00	71	44-00441-00	9	50-00230-00	42
42-00504-00	17	44-00442-00	11, 13	50-00232-09SV	39
42-00506-01	29	44-00443-00	11, 13	50-00236-05	39
42-00552-00	65	44-00443-01	11	50-00236-31	39
42-00584-00	79	44-00443-02	11, 13	50-00236-32	39
42-00606-01	34	44-00443-03	11	50-00236-33	39
42-00673-00	79	44-00443-04	11, 13	50-00240-00	40
42-00674-00	79	44-00443-06	11	50-01123-13	47, 49
42-00675-00	79	44-00445-00	13	50-01152-00	43, 45
42-00677-00	79	44-01028-13	1, 19	50-01152-02	35, 37
42-00678-00	79	44-01042-00	61	50-01152-22SV	37, 45
42-00679-00	79	44-01134-04	1, 19	50-01152-25SV	37, 45
42-00680-00	79	44-01134-08	1, 31	50-01152-26	37, 45
42-00688-00	15	44-01137-19	1, 51	50-01152-28	45
42-00690-00	15	44-01139-03	65	50-01152-52	37
42-00692-00	79	44-01140-06	1, 29	56-03757-00	24
42-01133-00	51, 53	44-01152-00	11, 13	56-03768-00	33
42-01170-01	93	44-01152-01	11, 13	56-03769-00	33
42-01170-07	31	44-01159-00	61	56-03770-00	33
42-01210-01	59	44-01161-00	11	56-06942-05	21
42-60113-00	63	44-01168-00	1, 51, 53	56-07257-03	25
44-00045-05	1, 58	44-01170-23	1, 57	56-07300-00	33
44-00045-20	1, 34	44-01170-36	2, 57	56-07401-00	33
44-00045-26	1, 77	44-01170-41	2, 57	56-07605-00	25
44-00102-01	1, 89	48-00267-00	37, 45	56-08061-00	23
44-00102-02	1, 51	48-00273-00	41	56-08080-00	24
44-00102-06	1, 73	48-00273-02	41	56-08081-00	33
44-00102-18	1, 53	48-00327-01	42	56-08086-00	25
44-00285-20	1, 19	48-00347-01	39	56-08087-01	22
44-00285-22	1, 19	48-00373-02	47	56-08089-00	21
44-00285-60	1, 19	48-00419-00	85	56-08092-00	21
44-00285-72	1	48-50005-00	42	56-08161-00	22
44-00293-06	1, 51, 53, 57	50-00162-25	1, 47	56-08180-00	21
44-00293-07	1, 51, 53	50-00178-19	1, 43	56-08433-00	22
44-00356-00	63	50-00178-24	1, 35		

PART NUMBER INDEX

PART NO.	PAGE NO.	PART NO.	PAGE NO.	PART NO.	PAGE NO
56-08434-00	22	58-01335-00	73	58-04657-00	71
56-08579-00	22	58-01337-00	77	58-04661-00	57
58-00065-14	31	58-01369-00	26	58-04661-01	57
58-00065-51	51	58-01372-00	85	58-04663-00	57
58-00065-62	39	58-01372-01	81	58-04697-00	65
58-00065-66	31	58-01372-02	83	58-04698-01	34
58-00065-76	73	58-04099-01	7	58-04700-01	34
58-00065-80	39	58-04099-02	7	58-04702-00	65
58-00079-00	31, 39, 57, 61, 73	58-04099-04	7, 81, 83, 85	58-04703-00	29
58-00079-02	31, 41, 42, 43, 51, 61, 65, 73, 77, 89	58-04099-06	7	58-04726-00	77
58-00253-00	26, 87	58-04194-00	9	58-04736-00	15
58-00253-01	77	58-04223-07	57	58-04736-01	15
58-00507-00	55	58-04223-08	57	58-04737-00	15
58-00508-99	51, 53, 55, 89	58-04223-09	57	58-04738-00	15
58-00511-13	63	58-04223-10	57	58-04738-01	15
58-00523-01	31	58-04223-11	57	58-04739-00	13
58-00616-01	85	58-04223-12	57	58-04741-00	11
58-00616-02	85	58-04339-00	71	58-04741-01	11
58-00616-16	77, 85	58-04340-00	71	58-04741-02	11
58-00658-00	53	58-04341-01SV	71	58-04742-00	13
58-00659-00	39, 53	58-04341-02SV	71	58-04742-01	13
58-00660-00	71	58-04342-00SV	71	58-04742-02	13
58-00712-15	2, 26, 87	58-04344-01SV	71	58-04743-00	13
58-00772-07	87	58-04385-00	71	58-04744-00	11
58-00793-00	31	58-04439-05	26	58-04744-01	11
58-00836-04	31	58-04439-06	26	58-04744-02	11
58-00848-00	51	58-04472-00SV	35	58-04744-03	11
58-00849-00	51	58-04478-00	61	58-04744-04	11
58-00858-00	41, 42, 43, 53, 73	58-04507-00	7, 61	58-04755-00	15
58-00869-00	25	58-04523-00	61	62-02139-01	73, 75
58-00915-00	53	58-04535-00	58	62-02140-00	75
58-01149-00	33	58-04538-00	57	62-02144-03	75
58-01214-00	79	58-04538-01	57	62-02146-02	75
58-01278-01	26	58-04538-02	57	62-02448-03	63
58-01333-08	51, 53, 73	58-04606-00	57	62-02450-00	75
		58-04606-01	57	62-02505-00	75
		58-04606-02	57	62-02509-00	75
		58-04652-00	34	62-03797-11	19
		58-04653-00	34		

PART NUMBER INDEX

PART NO.	PAGE NO.	PART NO.	PAGE NO.	PART NO.	PAGE NO
62-03958-00	75	68-10745-00	31	73-00334-20	87
62-04007-00	13, 53	68-11009-00	91	76-00295-06	4, 89
62-04074-00	57	68-11547-00	19	76-00510-25	77
62-04759-02	75	68-11579-00	7	76-00524-00	4
62-04759-03	75	68-11596-00	73	76-00535-01	4, 81
62-04759-04	75	68-11608-00	43	76-00542-00	4, 91
62-04759-05	75	68-12632-00	31	76-00554-00	4, 87
62-10334-00	63	68-12650-00	42	76-00556-00	4, 87
62-10784-00	13, 51	68-12666-00	17	76-00559-00	4, 81
62-10793-00	57	68-12676-00	31	76-00561-00	4, 73
62-10962-05	65	68-13125-00	81	76-00566-00	4, 55
62-11106-01	34	68-13157-00	19	76-00571-00	4, 83
62-11144-00	77	68-13636-00	29	76-00578-07	4
65-00168-22	21	68-13638-00	57	76-00578-08	97
65-00168-24	21	68-13651-00	19	76-00725-00	4, 93
65-00182-03	3, 21	68-13717-00	27	76-00725-01	4, 99
65-01085-21	21	68-13796-00	29	76-00725-02	4, 93
65-01085-22	21	68-13797-00	29	76-00725-03	4, 93
66U1-2233-33	49	68-14256-00	23	76-00792-00	85
66U1-3803	89	68-14422-00	47	76-00796-00	77
66U1-9752	63	68-14439-00	19	76-02000-00	4, 91
67-00051-00	93	68-14694-00	31	76-02001-00	4
68-06986-00	19	68-14771-00	53	76-60798-05	2, 95
68-07236-00	17	68-14894-00	51	76-60798-10	3, 95
68-07438-03	43	68-14943-00	7	76-60798-15	3, 95
68-07670-00	31	68-14944-01	7	76-60798-20	3, 95
68-07673-00	19	68-15092-00	35	76-60876-07	4, 95
68-07729-00	2, 31	68-15124-00	9	79-01935-00	11
68-07730-00	31	68-15125-00	9	79-01935-01	11
68-07818-00	29	68-15129-00	61	79-01935-02	11
68-07868-00	87	68-15130-00	9	79-01935-03	13
68-07876-00	7	68-15153-00	77	79-01935-04	13
68-07893-00	81	68-15314-00	15	79-01950-00	85
68-07902-00	11, 13	68-15333-00	37	79-02305-00	51, 53
68-07902-01	11, 13	73-00160-02	41	79-02343-00	81
68-07921-00	17	73-00201-00	3, 22	79-02349-00	83
68-08030-00	73	73-00328-10	3, 25	81-01653-01	4, 21, 33
68-08042-00	91	73-00334-00	87	81-01653-02	4, 21, 33
68-08076-00	17	73-00334-01	87	86-02803-02	19

PART NUMBER INDEX

PART NO.	PAGE NO.	PART NO.	PAGE NO.	PART NO.	PAGE NO
86-02924-00	11, 13	86-04437-00	40	86-04616-00	34
86-02992-00	85	86-04494-01	65	86-04620-00	7
86-03013-00	31	86-04547-00	53	86-04621-00	7
86-03054-00	81	86-04558-00	63	86-04661-00	58
86-03055-00	81	86-04565-00	19	86-04673-00	85
86-03061-00	73	86-04592-00	57	91-00312-02SV	63, 71
86-03083-00	83	86-04595-00	19	91-00343-02	61, 63, 65
86-04249-01	33	86-04614-00	13	91-00343-03	61, 63, 65
86-04257-01	19	86-04615-00	11, 13	91-60112-09	95
86-04390-00	26				



A member of the United Technologies Corporation family. Stock symbol UTX
©2006 Carrier Corporation • Printed in U. S. A. 1206



Carrier

A United Technologies Company

Carrier Transicold Division, Carrier Corporation
Truck/Trailer & Container Product Groups
P.O. Box 4805
Syracuse, N.Y. 13221 U.S.A

www.carrier.transicold.com